

MC-6 CABLE DRAWINGS

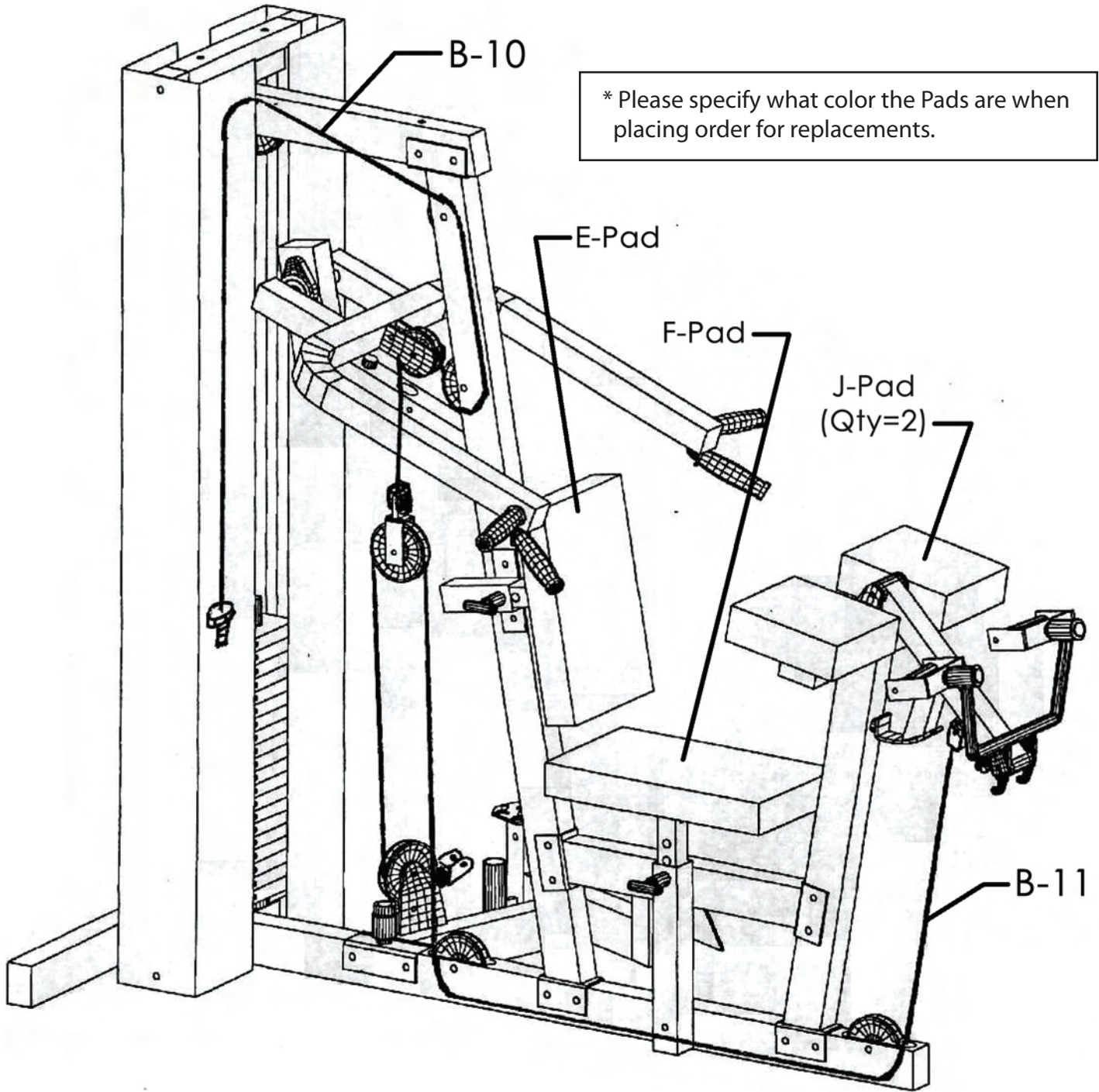

* Please specify what color the Pads are when placing order for replacements.

Part Number	Description	Qty
B-10	Weight Stack to Free Floater Cable	1
B-11	Low Pulley to Bicep Curl Cable	1
*E-Pad	Back Pad	1
*F-Pad	Seat Pad	1
*J-Pad	Arm Pad	2