



# LINK

DUAL FUNCTION

Revision 2

May 2021

## LD-6 Shoulder Press/ Low Pulley



Serial Number Here

Date of Purchase



# Instructions

Congratulations on the purchase of your new Batca LD-6 Shoulder Press/Low Pulley machine. This gym will provide you with a lifetime of enjoyment to meet your strength training needs. Batca Fitness Systems strives to build the best quality gyms and to package these gyms in such a way to avoid any damage during shipping.

In order to get started with your assembly you should first familiarize yourself with this manual. It is recommended that you read through each step thoroughly before you begin. Begin by opening your boxes and separating all of your parts. Verify that all parts are accounted for and have no damage. When all parts are accounted for, you may begin your assembly. Some items may have been pre-assembled for your convenience. Please note that hardware quantities shown reflect total quantities for your gym and may not reflect actual quantities in each bag. Assemble your gym on a solid level surface. This will ensure the best possible performance, function, and safety for the gym and your workout.

Assemble your gym according to the step by step instructions found in this manual. Failure to do so will void your warranty and may result in personal injury. After assembly, you should check each station to ensure correct operation. If a problem arises, recheck your assembly with these instructions to verify correct assembly. If you are unable to correct a problem or have questions with your assembly please contact your authorized Batca dealer.

## Warning

Batca Fitness Systems has built this gym to give you a safe, effective and enjoyable workout. However, there is a risk assumed by individuals who use this type of equipment. It is very important that all warnings and instructions are read and followed before beginning any exercise program.

It is also very important to read and follow the preventative maintenance schedule described in this manual. If any of the warning labels or stickers are worn, faded, torn, scratched or missing they should be replaced immediately.

**WARNING: There is a risk assumed by individuals who use this type of equipment. To minimize risk always follow these rules.**

- 1) It is essential that you consult with your physician before beginning any exercise program.
- 2) Inspect equipment before each use for loose, worn, or frayed parts (including cables, nuts and bolts). Replace parts at first signs of wear (use only genuine BATCA replacement parts). Use of equipment that is damaged, worn, frayed or not completely assembled on a solid, level surface may result in injury.
- 3) Make sure all adjustment pins are fully engaged before using equipment.
- 4) Keep all parts of the body and clothing outside the path of any moving parts of the gym. Be alert to the possibility of injury. Do not be careless.
- 5) Minors and children should not be allowed to play on or around this gym.
- 6) If you have any questions on proper use or maintenance of this gym, do not hesitate to call your local BATCA FITNESS SYSTEMS distributor or BATCA FITNESS SYSTEMS at (919) 255-1233. [www.batcafitness.com](http://www.batcafitness.com)

## Table of Contents

	<u>Page</u>		<u>Page</u>
Instructions	2	Final Assembly and Troubleshooting	15
Parts Listing	3-4	Cable Tension and Adjustments	16
Main Assembly	5-9	Maintenance	17
	13-14	Warranty	18
Cable Routing	10-11	Floor Plan Layout	19
Upholstery	12		

# Tools Required

- 9/16" Wrench/Ratchet
- Metric Allen Wrench Set (M8, M6, M4)
- 3/4" Wrench
- Tape Measure

# Hardware Blister Pack

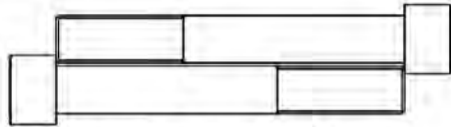
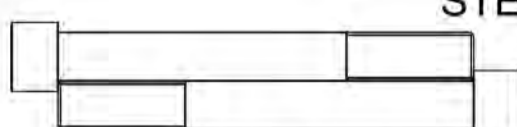
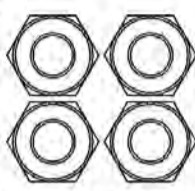
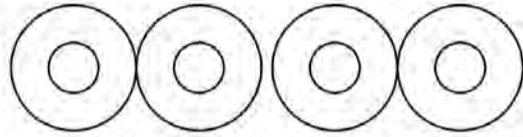
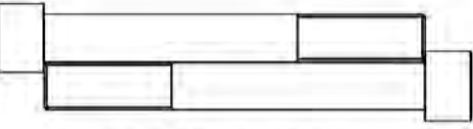
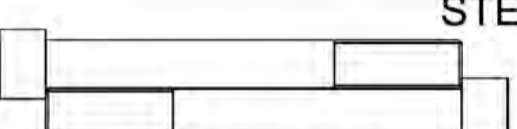
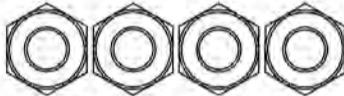
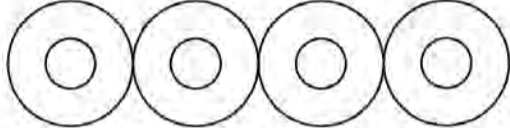
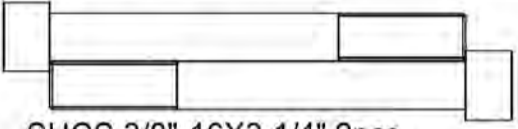
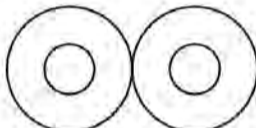
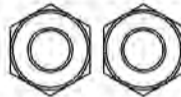
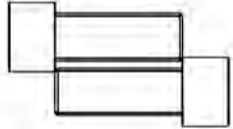
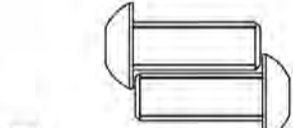
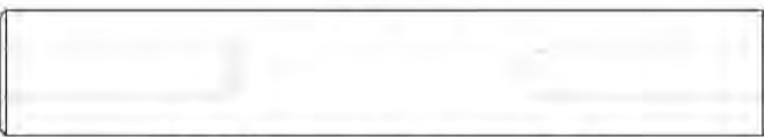
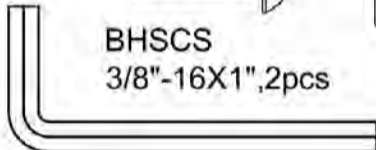
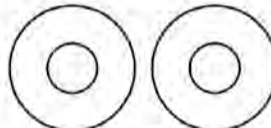
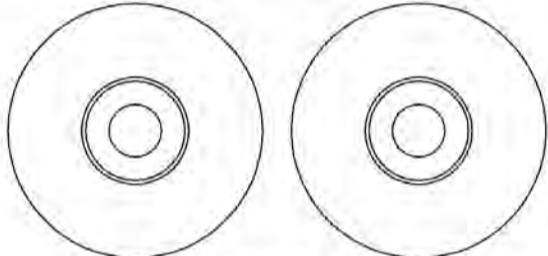
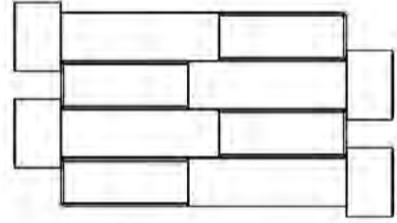
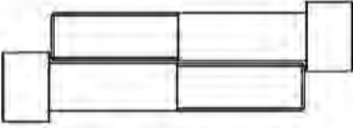
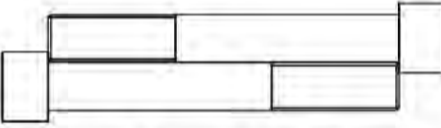
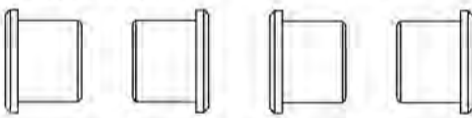
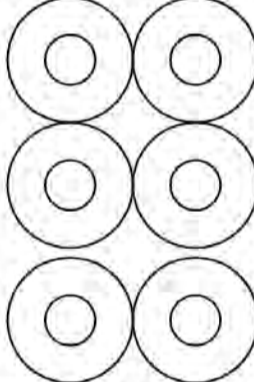
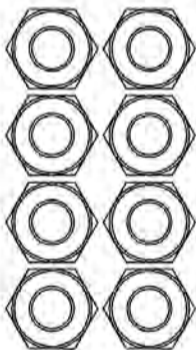
 <p>SHCS 3/8"-16X2-3/4", 2pcs</p>		 <p>SHCS 3/8"-16X3-1/4", 2pcs</p>		<p><b>STEP 1:</b></p>  <p>3/8"-16 Nylock, 4pcs</p>	 <p>M8 3/8" Flat Washers, 8pcs</p>
 <p>SHCS 3/8"-16X3", 2pcs</p>		 <p>SHCS 3/8"-16X3-1/4", 2pcs</p>		 <p>3/8"-16 Nylock, 4pcs</p>	 <p>3/8" Flat Washers, 8pcs</p>
 <p>SHCS 3/8"-16X3-1/4", 2pcs</p>		 <p>3/8" Flat Washers, 4pcs</p>		 <p>3/8"-16 Nylock, 2pcs</p>	
 <p>SHCS 3/8"-16X1", 2pcs</p>		 <p>BHSCS 3/8"-16X1", 2pcs</p>		<p><b>STEP 4:</b></p>  <p>Axle, 1pc</p>	
 <p>M6</p>		 <p>3/8" Flat Washers, 2pcs</p>		 <p>Small Aluminum Cap, 2pcs BFP-51696</p>	
 <p>SHCS 3/8"-16X2-1/4", 4pcs</p>		 <p>SHCS 3/8"-16X2", 2pcs</p>		 <p>SHCS 3/8"-16X2-3/4", 2pcs</p>	
		 <p>1/2" Pulley Spacer, 4pcs BFP-51946</p>		 <p>3/8" Flat Washers, 10pcs</p>	
				 <p>3/8"-16 Nylock, 8pcs</p>	

# Hardware Blister Pack

## STEP 7:

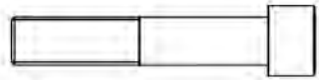

SHCS 3/8"-16X2", 1pcs

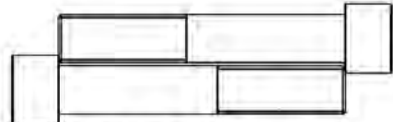

SHCS 3/8"-16X2-1/4", 2pcs

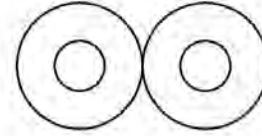

3/8" Flat Washers, 4pcs

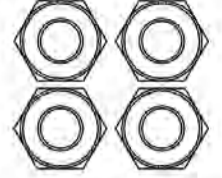

3/8"-16 Nylock, 4pcs

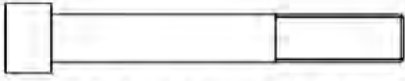

SHCS 3/8"-16X2-3/4", 1pc

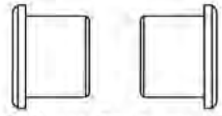

1/2" Pulley Spacer, 2pcs

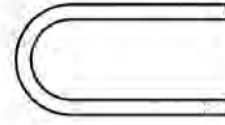

BTH-50227  
Cable Strap, 1pc

## STEP 8:

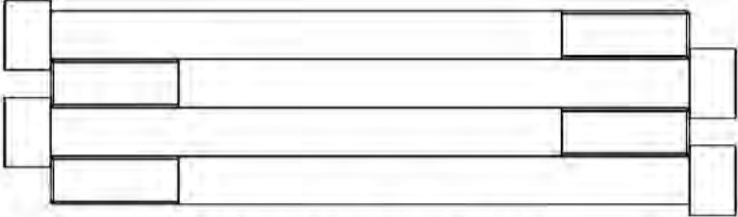

SHCS 3/8"-16X5", 4pcs

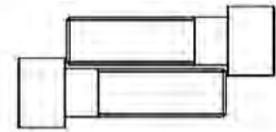

SHCS 3/8"-16X1-1/4", 2pcs

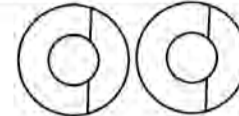

3/8" Curved Washers, 4pcs



3/8" Lock Washers, 6PCS

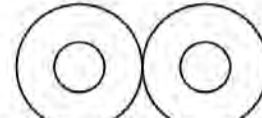

3/8" Flat Washers, 2pcs

## STEP 9:

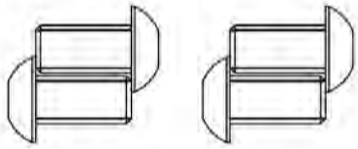

BHSCS 3/8"-16X3/4", 4pcs

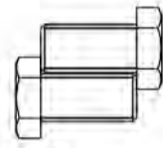

HCS  
3/8"-16X3/4", 2pcs

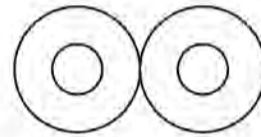

3/8" Flat Washers, 4pcs

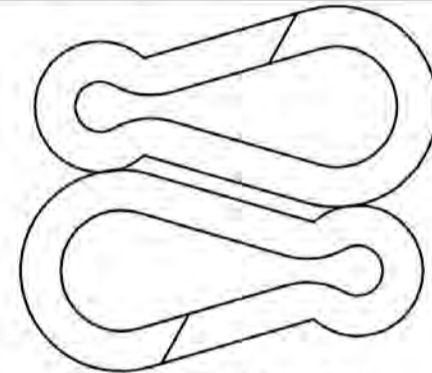

Snap Hook, 2pcs  
BFH-50188

**PLEASE READ AND FOLLOW ALL DIRECTIONS VERY CAREFULLY FOR PROPER INSTALLATION.**



**Step 1:**

**Note: Please Position Hardware in the same direction as shown in the figure. This will make future steps easier to assemble**

**All Flat Washers and Nylocks are 3/8" unless otherwise noted. Anywhere a washer is against the round side of a tube there is to be a 3/8" CURVED WASHER instead of a 3/8" FLAT WASHER.**

**DO NOT TIGHTEN BOLTS UNTIL STEP 2**

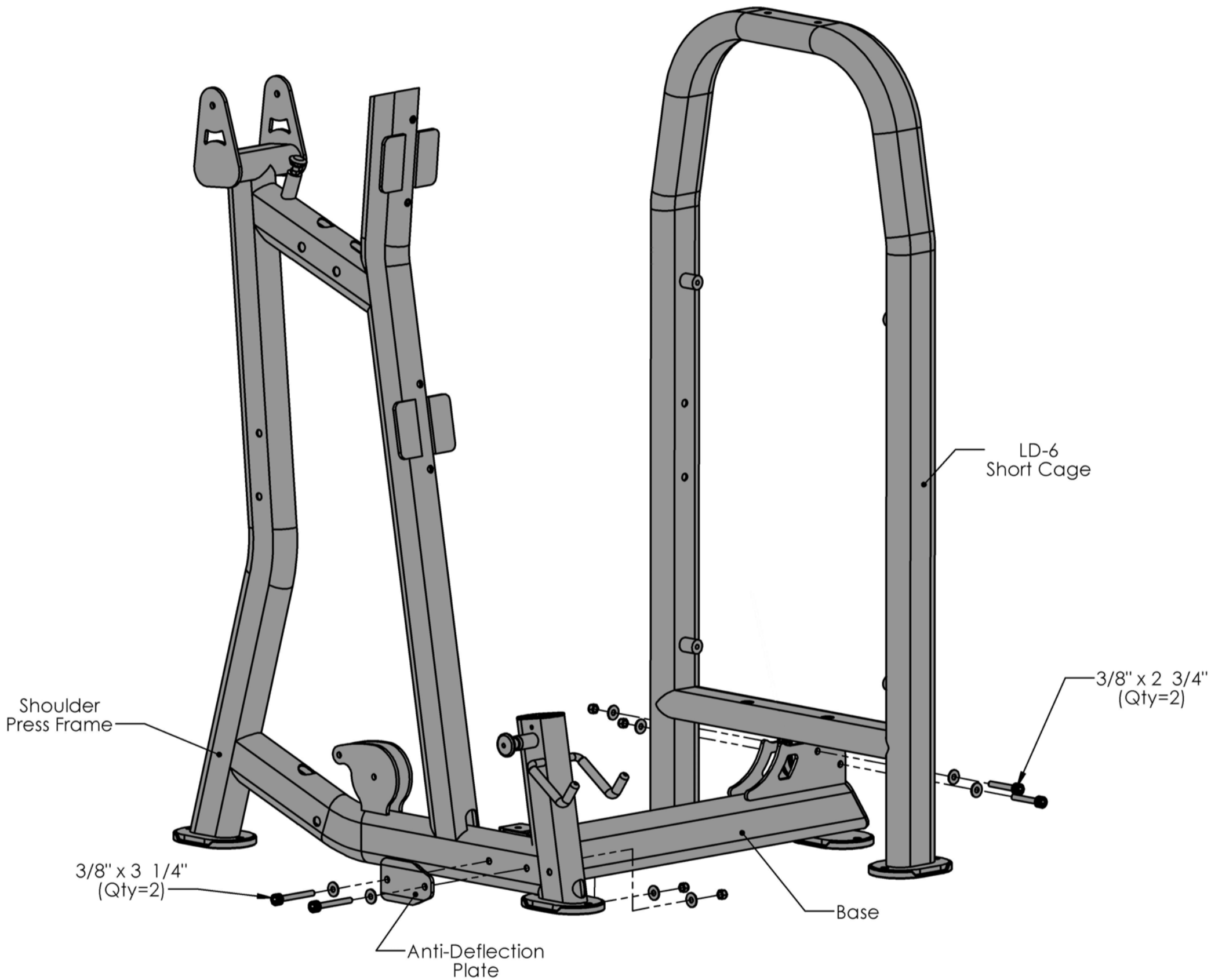

Item #	Part #	Description	Qty
1	BFP-10887	LD-6 Short Cage	1
2	BFP-10885	Base	1
3	BFP-10884	Shoulder Press Frame	1
4	BFP-51842	Anti-Deflection Plate	1
43	BFP-51750	SHCS 3/8" x 2 3/4"	2
45	BFP-51748	SHCS 3/8" x 3 1/4"	2
49	BFH-50146	3/8" Flat Washer	8
50	BFH-50157	3/8" Nylock	4

## Step 2:



**DO NOT TIGHTEN BOLTS UNTIL STEP 3**

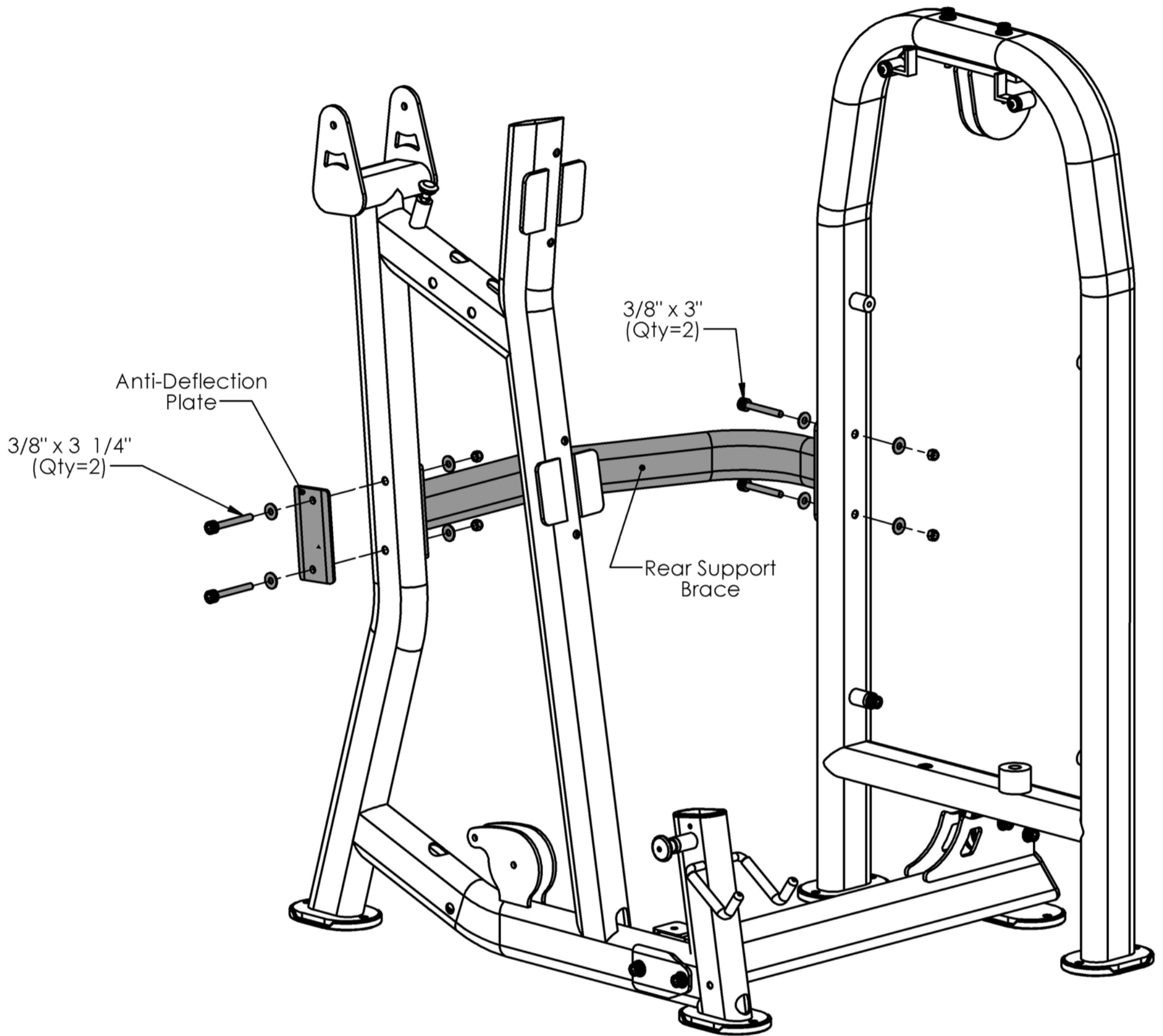

All Flat Washers and Nylocks are 3/8" unless otherwise noted. Anywhere a washer is against the round side of a tube there is to be a **3/8" CURVED WASHER** instead of a **3/8" FLAT WASHER**.

Item #	Part #	Description	Qty
5	BFP-10886	Rear Support Brace	1
6	BFP-51945	Anti Deflection Plate	1
44	BFP-51747	SHCS 3/8" x 3"	2
45	BFP-51748	SHCS 3/8" x 3 1/4"	2
49	BFH-50146	3/8" Flat Washer	8
50	BFH-50157	3/8" Nylock	4

## Step 2:



**Make sure all bolts are tightened before moving on**

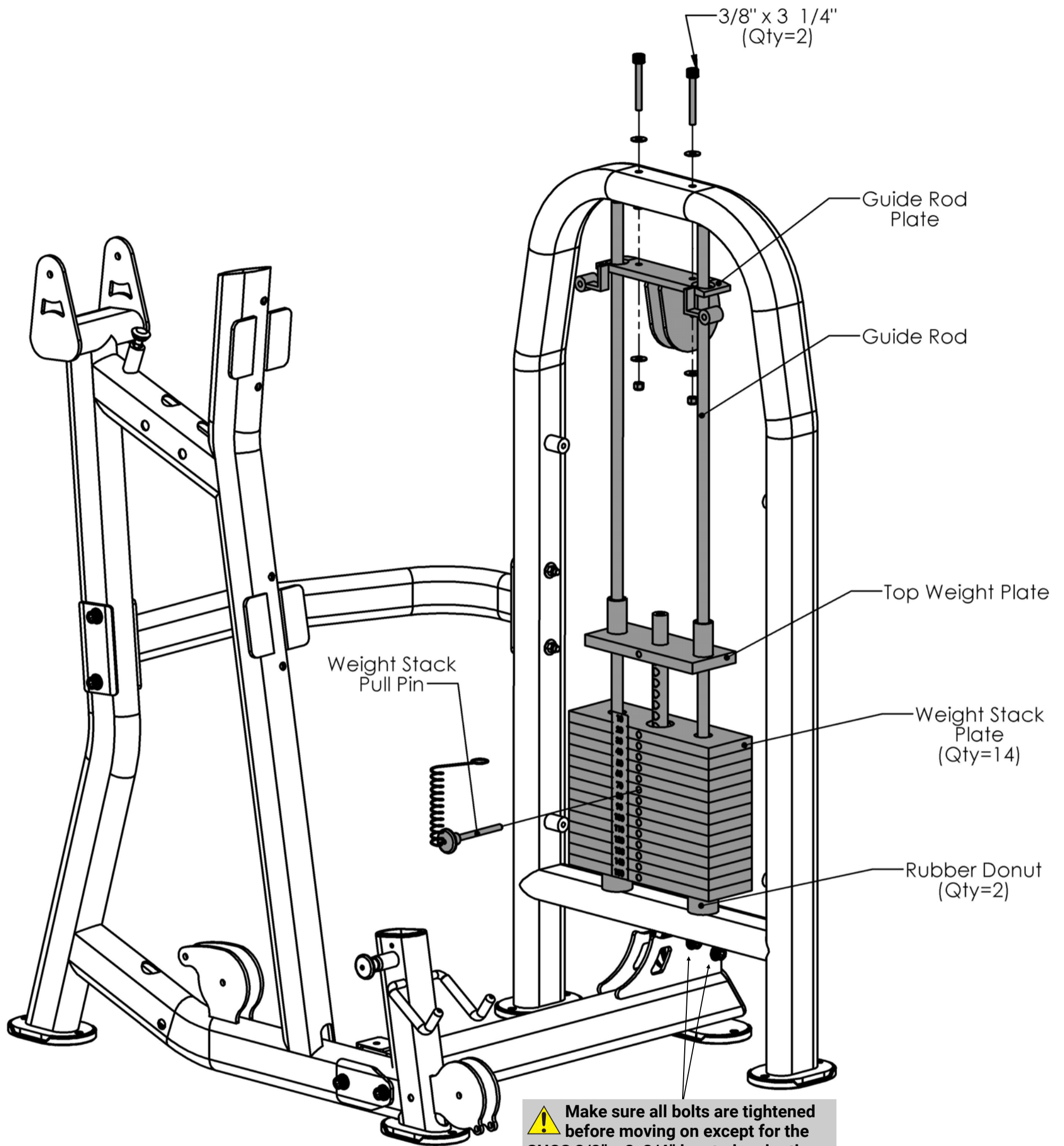

**!** Make sure all bolts are tightened before moving on except for the SHCS 3/8" x 2 3/4" located under the cage. You will need to remove these two bolts in Step 6 when you are ready to route the cable. Right now they are being used to make sure the assemblies are in the correct location.

Item #	Part #	Description	Qty
7	BFP-10888	Guide Rod Plate	1
8	BFP-51827	Guide Rod	2
9	BFP-10889	Top Weight Plate	1
10	BFM-50632	Weight Stack Plate	14
11	BFM-50529	Rubber Donut	2
24	BFM-51173	Weight Stack Pull Pin	1
45	BFP-51748	SHCS 3/8" x 3 1/4"	2
49	BFH-50146	3/8" Flat Washer	4
50	BFH-50157	3/8" Nylock	2

All Flat Washers and Nylocks are 3/8" unless otherwise noted.

## Step 4:



**Make sure all bolts are tightened before moving on**

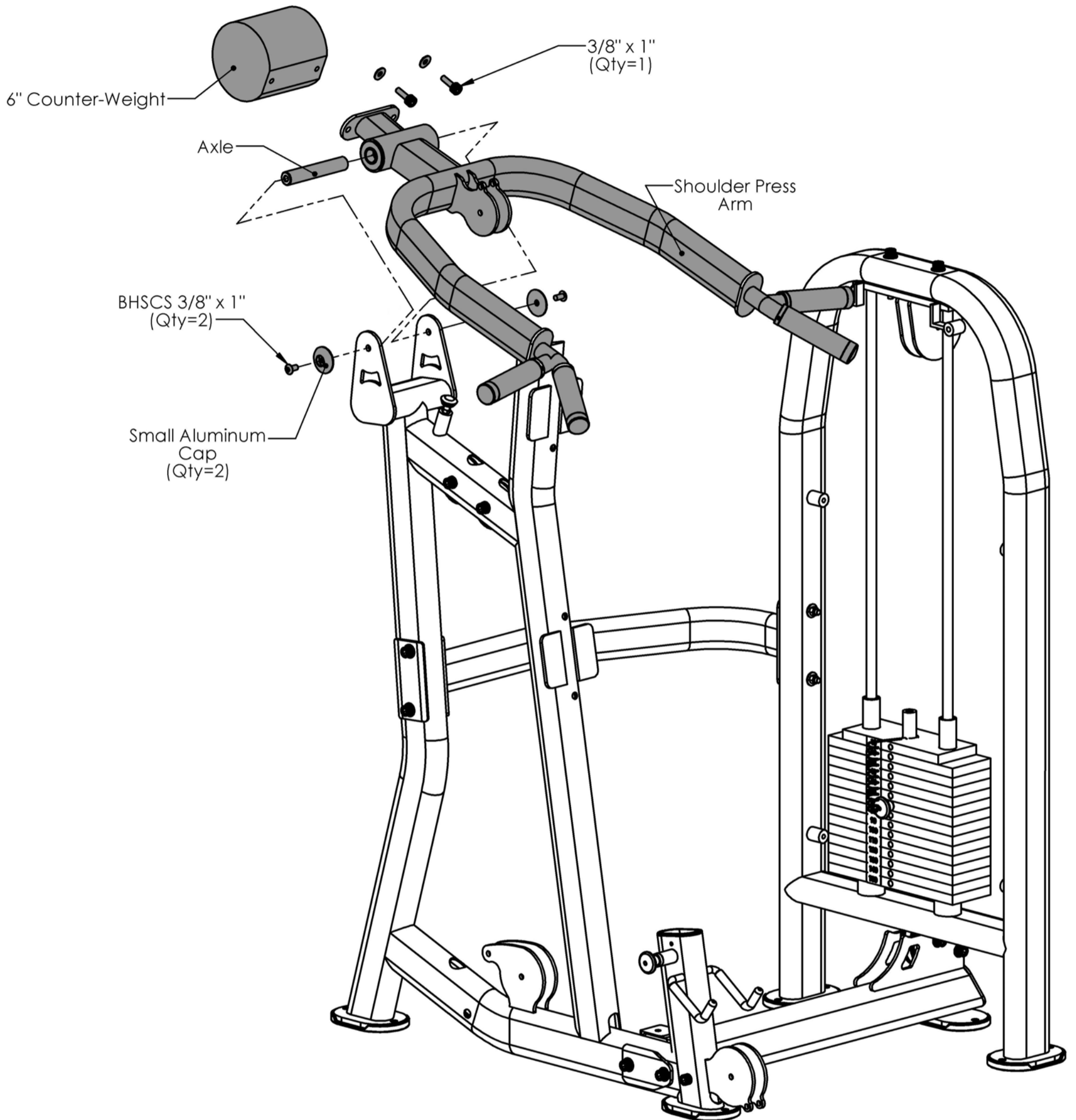

All Flat Washers and Nylocks are 3/8" unless otherwise noted.

Item #	Part #	Description	Qty
12	BFP-10890	Shoulder Press Arm	1
13	BFP-51776	Axle	1
14	BFP-51944	6" Counter-Weight	1
32	BFP-51696	Small Aluminum Cap	2
38	BFH-50620	BHSCS 3/8" x 1"	2
39	BFP-52376	SHCS 3/8" x 1"	2
49	BFH-50146	3/8" Flat Washer	2



**Step 5:**

**⚠ Make sure all bolts are tightened before moving on**

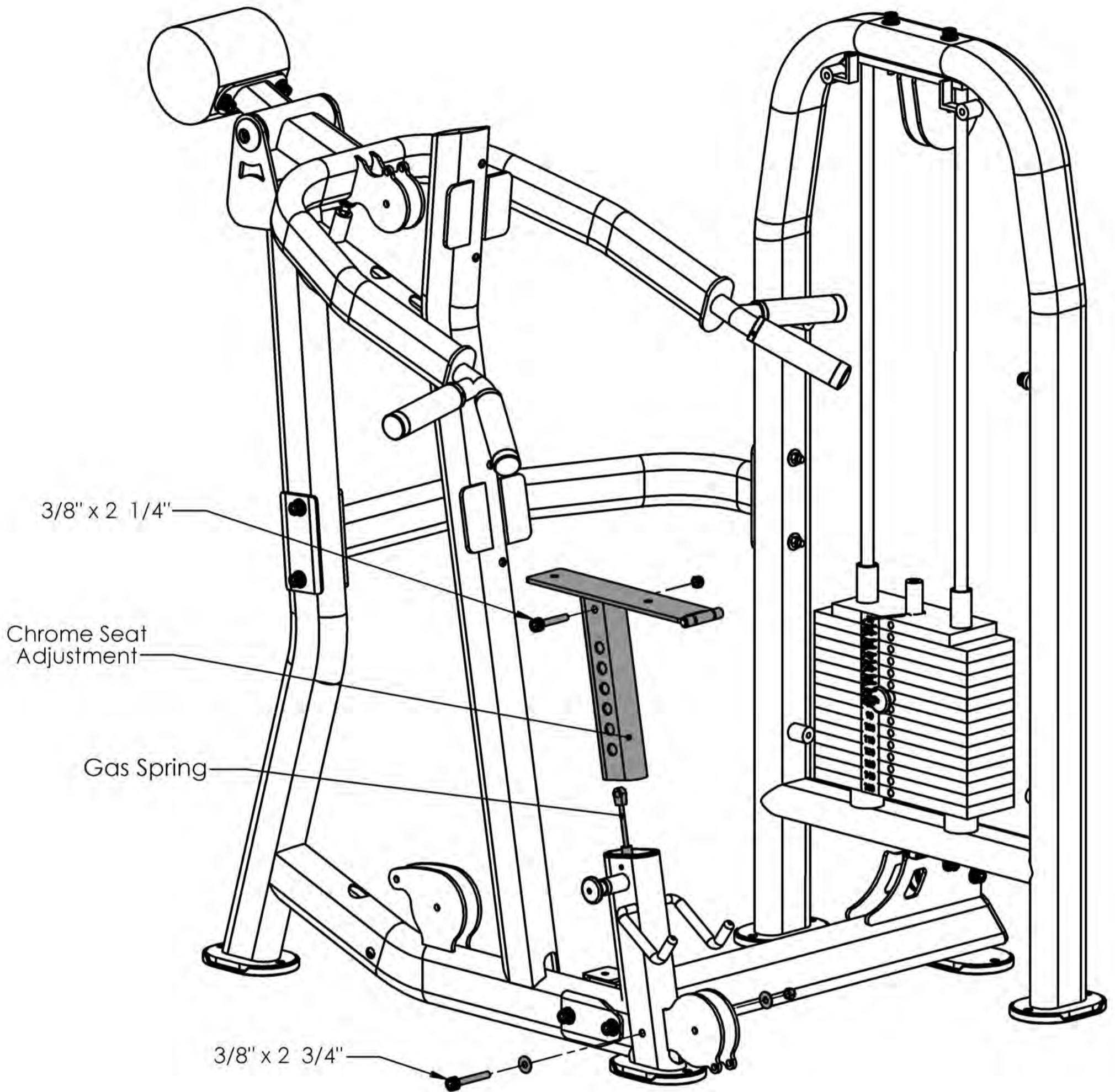

All Flat Washers and Nylocks are 3/8" unless otherwise noted.

Item #	Part #	Description	Qty
15	BFP-10891	Chrome Seat Adjustment	1
33	BFH-50210	Gas Spring	1
42	BFP-51752	SHCS 3/8" x 2 1/4"	1
43	BFP-51750	SHCS 3/8" x 2 3/4"	1
49	BFH-50146	3/8" Flat Washer	2
50	BFH-50157	3/8" Nylock	2

## Step 6:



**Make sure all bolts are tightened before moving on**

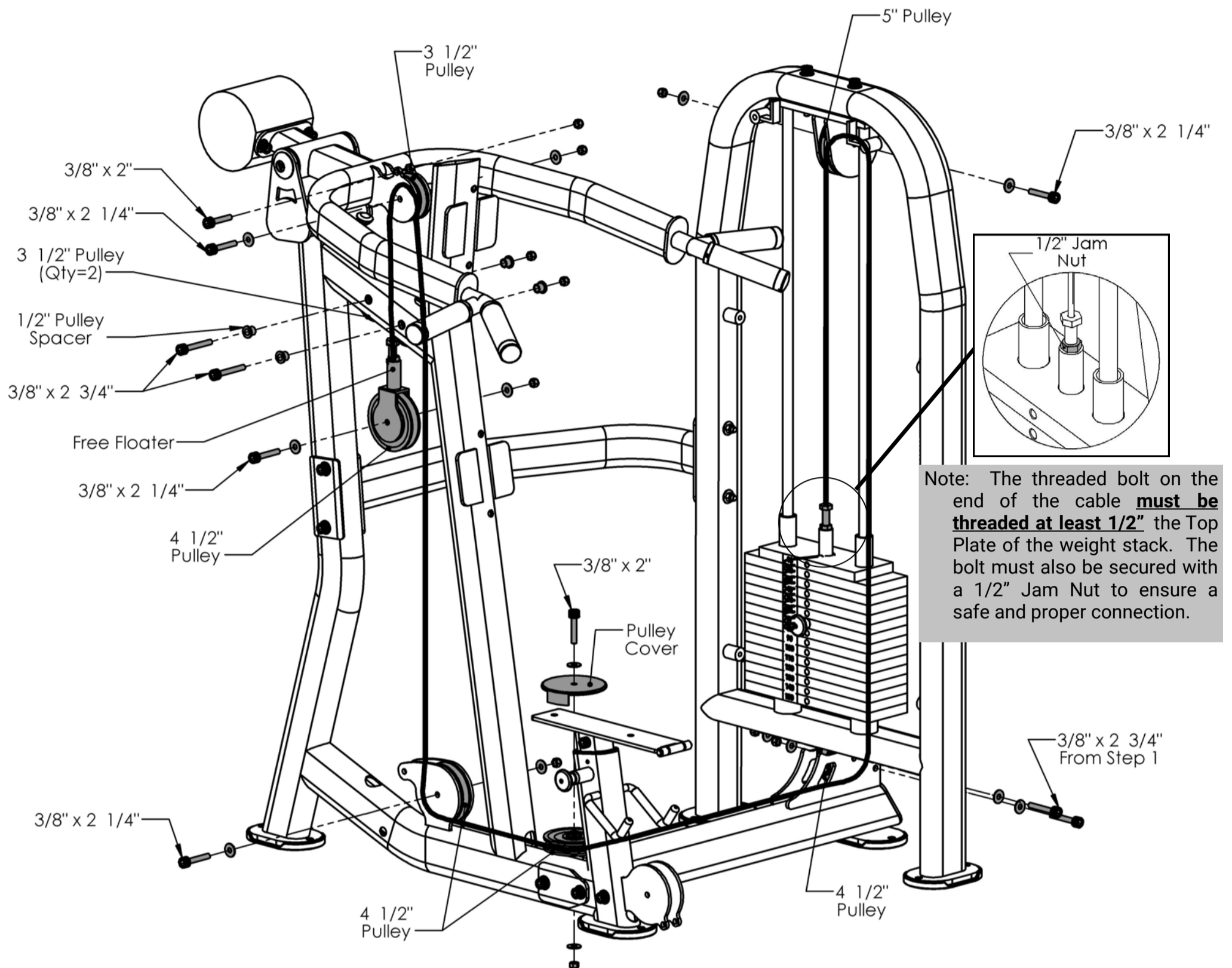

Note: The threaded bolt on the end of the cable **must be threaded at least 1/2"** the Top Plate of the weight stack. The bolt must also be secured with a 1/2" Jam Nut to ensure a safe and proper connection.

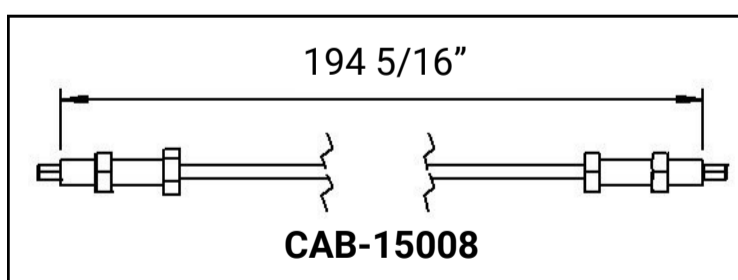

- **Position** the cable guard tab on the Pulley Cover so that the tab prevents the cable from coming out of its track on the 4 1/2" Pulley. An example of this positioning can be seen in the figure above. The cable guard tab should be positioned so that it is in the middle of the cable wrap on the 4 1/2" Pulley, between points "A" and "B". This will allow better protection and prevent the cable from rubbing the cable guard tab.

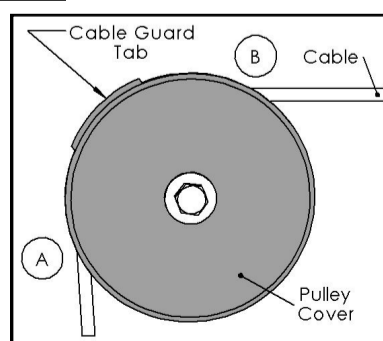

Item #	Part #	Description	Qty
22	CAB-15008	Weight Stack to Free Floater	1
16	BFP-10838	Free Floater	1
17	BFM-50345	Pulley Cover	1
29	BFH-50173	3 1/2" Pulley	3
30	BFH-50174	4 1/2" Pulley	3
31	BFH-50530	5" Pulley	1
41	BFP-51759	SHCS 3/8" x 2"	2
42	BFP-51752	SHCS 3/8" x 2 1/4"	4
43	BFP-51750	SHCS 3/8" x 2 3/4"	2
47	BFP-51946	1/2" Pulley Spacer	4
49	BFH-50146	3/8" Flat Washer	10
50	BFH-50157	3/8" Nylock	8

All Flat Washers and Nylocks are 3/8" unless otherwise noted.

## Step 7:



**Make sure all bolts are tightened before moving on**

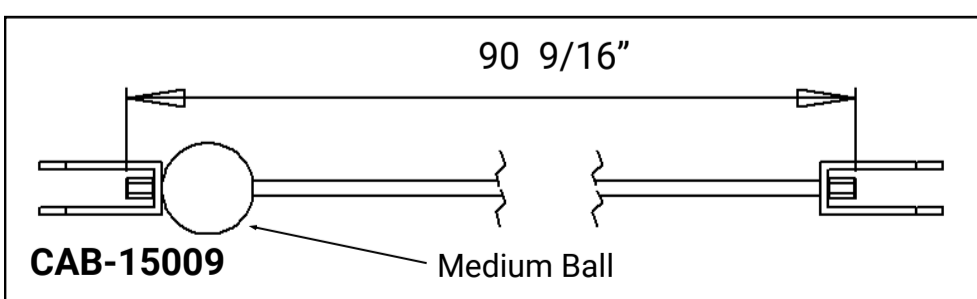
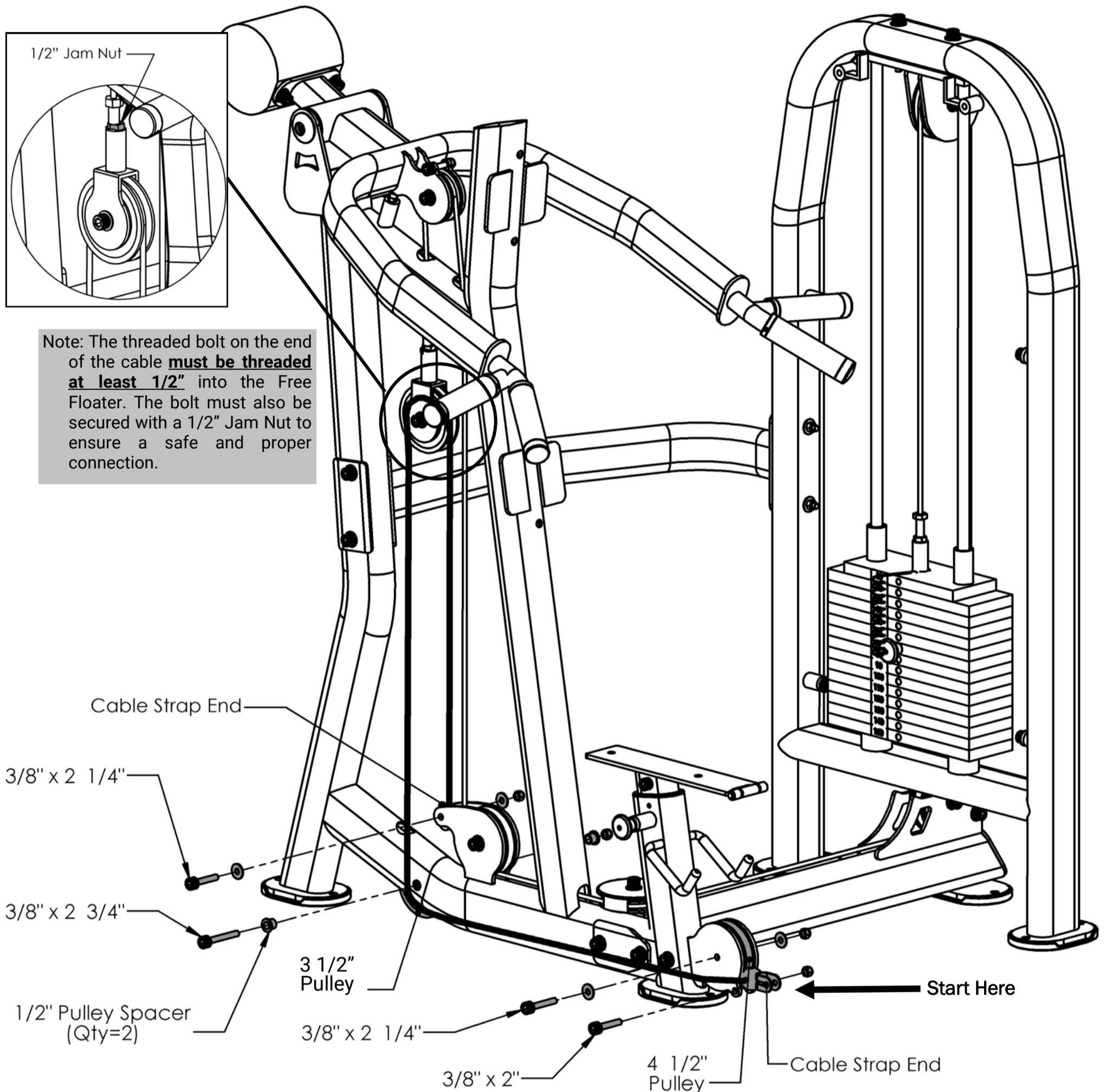

All Flat Washers and Nylocks are 3/8" unless otherwise noted.

Item #	Part #	Description	Qty
23	CAB-15009	Cable Lockout to Low Pulley	1
29	BFH-50173	3 1/2" Pulley	1
30	BFH-50174	4 1/2" Pulley	1
41	BFP-51759	SHCS 3/8" x 2"	1
42	BFP-51752	SHCS 3/8" x 2 1/4"	2
43	BFP-51750	SHCS 3/8" x 2 3/4"	1
47	BFP-51946	1/2" Pulley Spacer	2
49	BFH-50146	3/8" Flat Washer	4
50	BFH-50157	3/8" Nylock	4
52	BFH-50227	Cable Strap	2

## Step 8:



Make sure all bolts are tightened before moving on

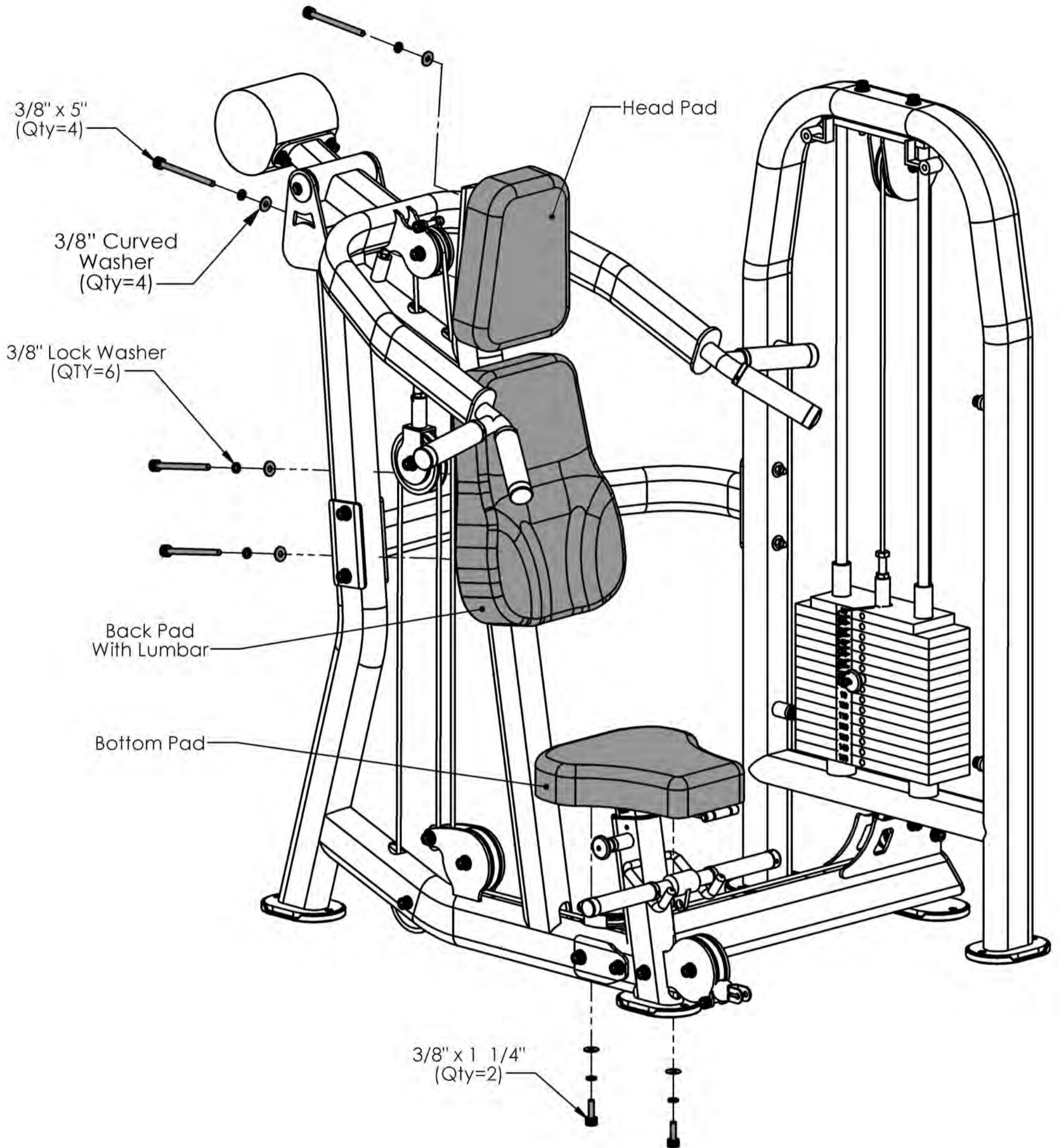

All Flat Washers and Nylocks are 3/8" unless otherwise noted. Anywhere a washer is against the round side of a tube there is to be a **3/8" CURVED WASHER** instead of a **3/8" FLAT WASHER**.

Item #	Part #	Description	Qty
26	BFP-52137	Head Pad	1
27	BFP-52136	Back Pad With Lumbar	1
28	BFP-52141	Bottom Pad	1
40	BFP-51653	SHCS 3/8" x 1 1/4"	2
46	BFP-51799	SHCS 3/8" x 5"	4
48	BFH-50204	3/8" Curved Washer	4
51	BFH-50147	3/8" Lock Washer	6
49	BFH-50146	3/8" Flat Washer	6

## Step 9:



**Make sure all bolts are tightened before moving on**

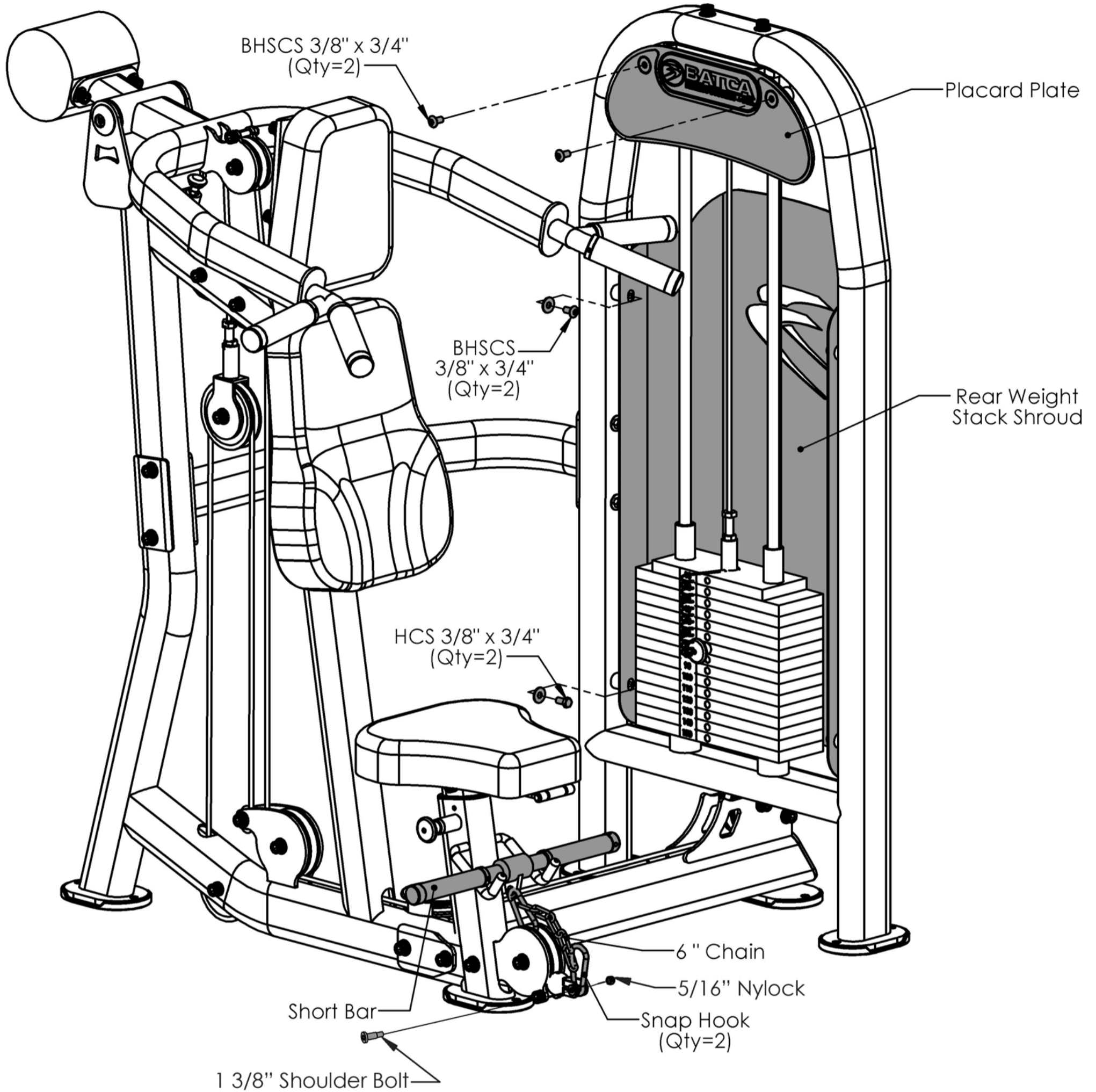

Item #	Part #	Description	Qty
18	BFP-51711	Placard Plate	1
19	BFP-51740	Rear Weight Stack Shroud	1
25	BFC-50126	Short Bar	1
35	6xBFC-50128	6x 1" inch link Chain	1
34	BFH-50188	Snap Hook	2
36	BFP-52430	BHSCS 3/8" x 3/4"	4
37	BFH-50254	HCS 3/8" x 3/4"	2
49	BFH-50146	3/8" Flat Washer	4
53	BFM-51464	Ankle Strap	1
54	BFH-50351	1 3/8" Shoulder Bolt	1
55	BFH-50267	5/16" Nylock	1

All Flat Washers and Nylocks are 3/8" unless otherwise noted.

# Step



Make sure all bolts are tightened before moving on

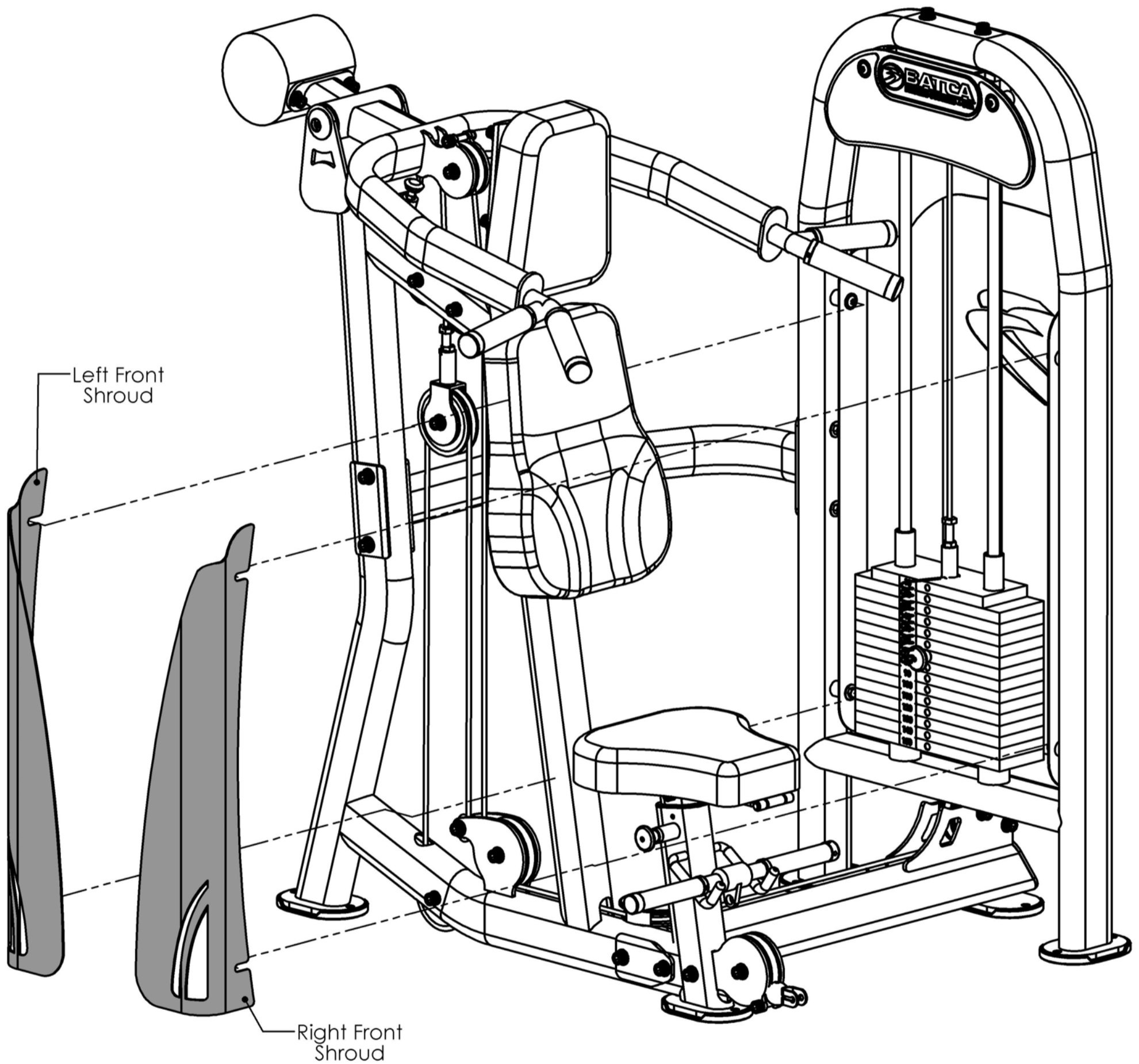

All Flat Washers and Nylocks are 3/8" unless otherwise noted.

Item #	Part #	Description	Qty
20	BFP-51741	Left Front Shroud	1
21	BFP-51742	Right Front Shroud	1

# Final Assembly and Troubleshooting

## Weight Stack Decals:

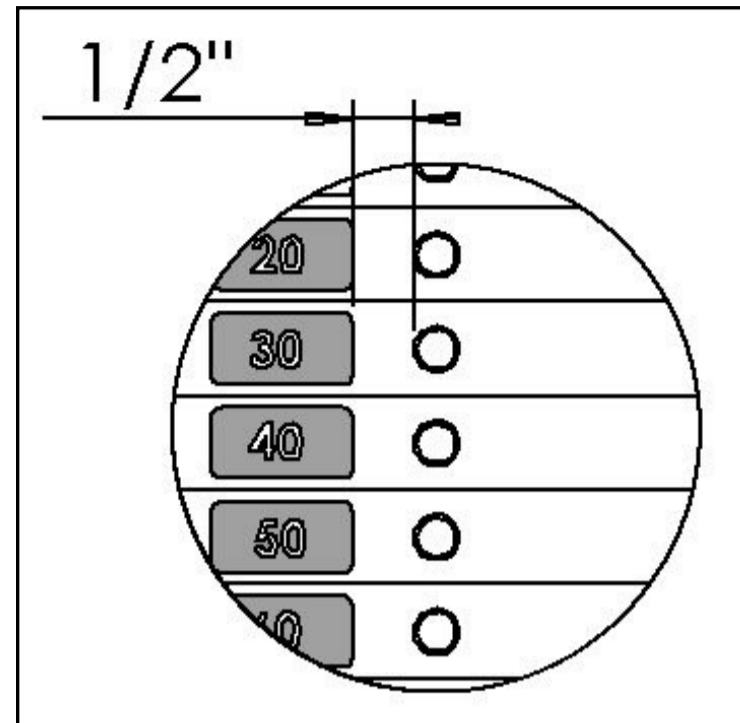
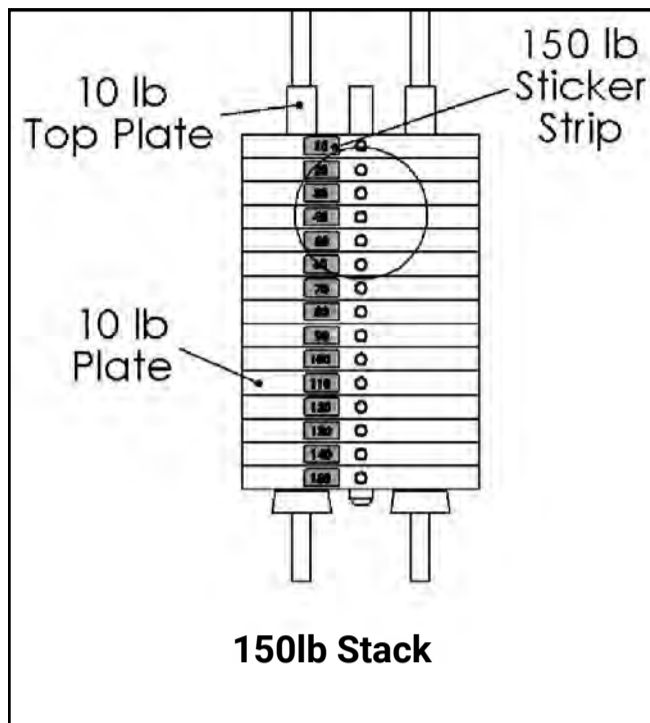

## IMPORTANT - Check These Components Before Using

- Each Cable with a threaded bolt on either end **must be threaded at least 1/2"** into its attachment, whether it be a Free Floater, Lockout Free Floater, or the Top Plate of the weight stack. Each must also be secured with a 1/2" Jam Nut to ensure a safe and proper connection.

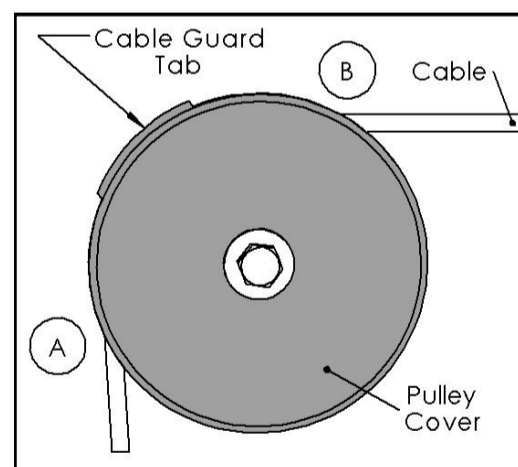
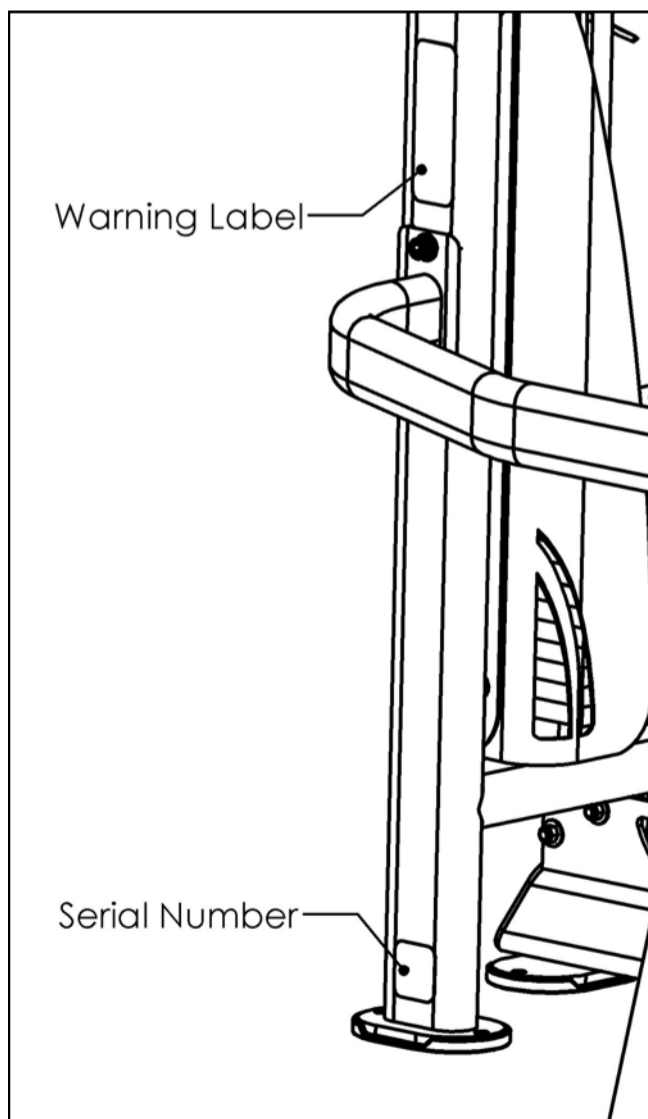
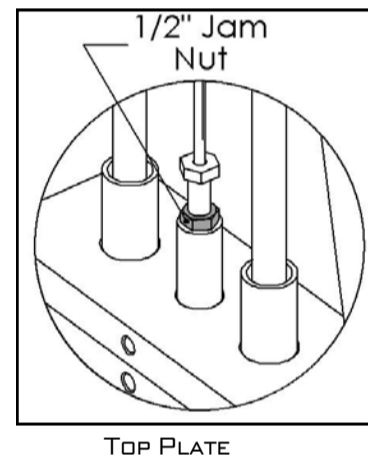

- Position** the cable guard tab on the Pulley Cover so that the tab prevents the cable from coming out of its track on the 4 1/2" Pulley. An example of this positioning can be seen in the figure to the left. The cable guard tab should be positioned so that it is in the middle of the cable wrap on the 4 1/2" Pulley, between points "A" and "B". This will allow better protection and prevent the cable from rubbing the cable guard tab.
- Record** your serial number on the front of this manual and keep for your records. The serial number can be found on the side of the cage as seen in the figure to the left.

## Guide Rod

- Clean guide rods with a lint-free cloth and apply a thin layer of silicone lubricant (Part # BFH-50262) to each guide rod. This will ensure a glass smooth performance from your weight stack.

# Cable Adjustments

- **Adjust** cables to proper tension from any of the locations shown below.

**!** **Note:** All cables with threaded adjustable ends must have at least 1/2" of the threads threaded in to its counterpart. It is very important that the 1/2" Jam Nut be wrench tightened to the counterpart to ensure that the threaded adjustable end of the cable does not back out of its counterpart.

- **Note:** If the top plate raises off of the second plate in the weight stack, then the cable tension is too tight. You will need to take some of the tension out to lower the Top plate flush with the second plate.

Fine Adjustments to the cable can be made here. It is very important to tighten the jam nut after adjustments have been made

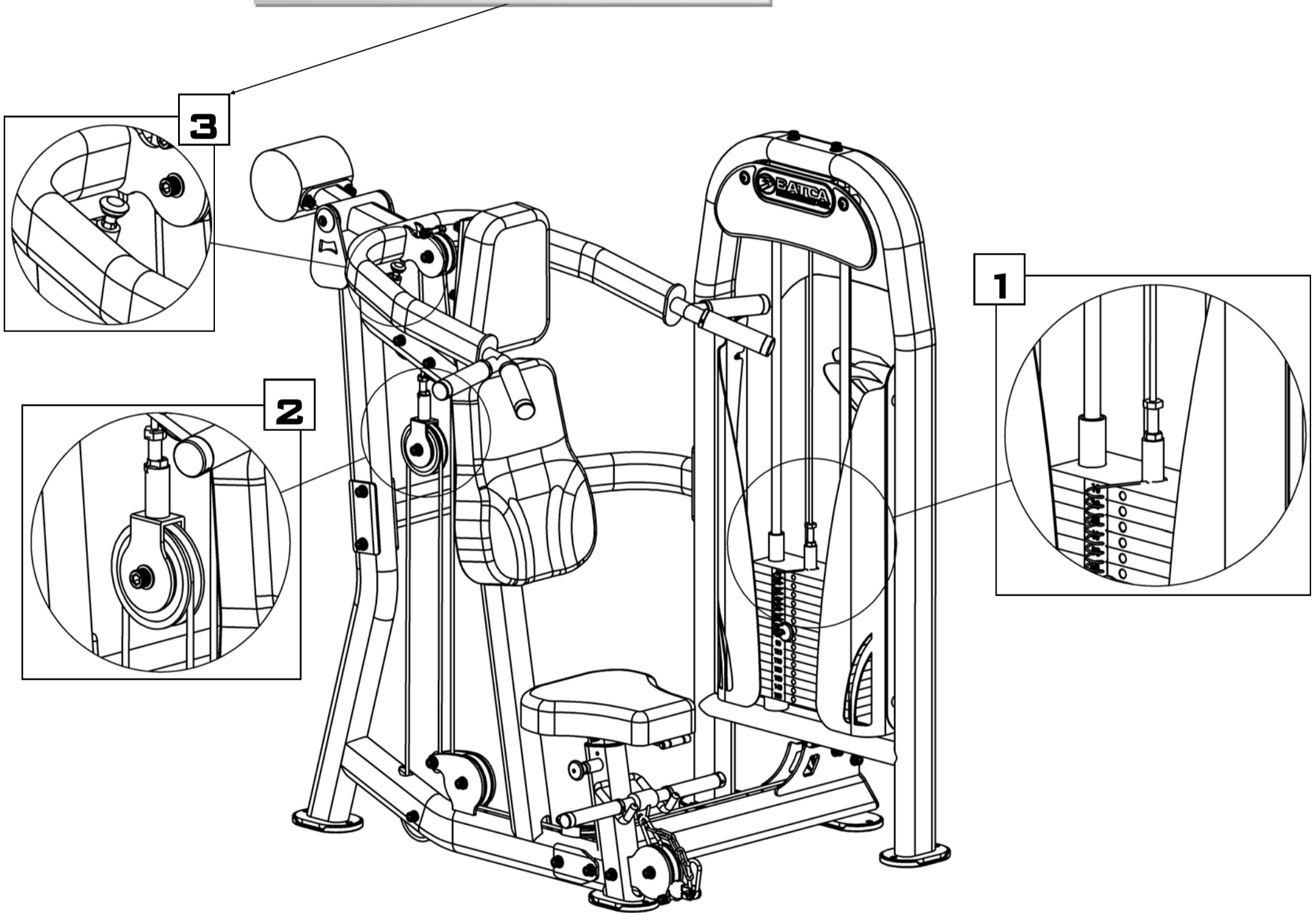



# Preventive Maintenance

Batca Fitness Systems strives to give you the very best in quality, performance and safety through carefully engineered designs and excellent workmanship. In order to maintain this high level of quality the preventative maintenance schedule below should be followed.

Clean upholstery, grips, and roller pads with mild soap and water generally after every use. The guide rods, chrome slides and frame should be cleaned with a cotton cloth. Upon cleaning the guide rods, a thin layer of Silicone or Teflon gel should be applied to each rod to ensure a glass smooth performance.

An overall inspection should be done before each workout. If the warning and safety decals are worn or have been removed they should be replaced immediately. The cables and cable systems should be inspected for signs of wear and proper tension. In order to check cables properly you should carefully run the cable through your fingertips, checking for signs of wear, cracks, burs and thinning spots. Replace any part at first signs of wear. Cables should be adjusted for proper tension. See assembly instructions for this detail. All hardware, stops, and adjustments should be checked and tightened as required.

The guide rods on your machine should be cleaned and lubricated regularly. This will ensure a glass smooth performance from your weight stack. A thin layer of either Silicone or Teflon gel should applied to each rod.

Although cables should be inspected daily, it is important that ALL cables be replaced as directed in the schedule below. Please note that at any first sign of wear the cable should be replaced immediately.

If there are any questions concerning maintenance, please contact your local Batca dealer or contact Batca Fitness Systems directly at:

Batca Fitness Systems  
(919) 255-1233  
www.batcafitness.com

	Daily		Weekly		Monthly		Quarterly		Years	
	Commercial	Home	Commercial	Home	Commercial	Home	Commercial	Home	Commercial	Home
<b>Clean</b>										
Upholstery	X			X						
Hand Grips	X			X						
Roller Pads	X			X						
Guide Rods			X			X				
Chrome Slides			X			X				
Frame			X			X				
<b>Inspect</b>										
Overall	X	X								
Safety Decals	X	X								
Cables	X	X								
Cable Tension			X			X				
Pulleys	X	X								
Hardware	X	X								
Stops	X	X								
Upholstery	X	X								
Hand Grips			X			X				
Frame			X			X				
Bushings	X			X						
Bearings	X			X						
<b>Lubricate</b>										
Guide Rods			X			X				
Bearings							As Needed			1
<b>Replace</b>										
Cables									1	3

# Limited Lifetime Warranty

## **What is covered**

### For Residential Use:

Batca Fitness Systems warrants all of its products against defects in manufacturing, materials and workmanship under normal use and service for one year from date of purchase including paint, chrome, upholstery and grips. Batca Fitness Systems also warrants all cables, belts, bolts, nuts, caps, plugs, bumpers, washers, levelers, decals, gas springs and other hardware for three years after date of purchase; all moving parts, including pulleys, bushings, bearings and pull pins for five years after date of purchase and warrants the frame and all welded parts for the lifetime of the original purchaser.

### For Commercial Use:

Batca Fitness Systems warrants all of its products against defects in manufacturing, materials and workmanship under normal use and service for six months from date of purchase including paint, chrome, upholstery and grips. Batca Fitness Systems also warrants all cables, belts, bolts, nuts, caps, plugs, bumpers, washers, levelers, decals, gas springs and other hardware for one year after date of purchase; all moving parts, including pulleys, bushings, bearings and pull pins for three years after date of purchase and warrants the frame and all welded parts for ten years after date of purchase.

## **What is not covered**

This warranty does not cover damage, which results from shipping, misuse, abuse, neglect, carelessness, modification or alteration, accident, fire, flood, "acts of God" or other contingencies beyond the control of Batca Fitness Systems. This warranty also does not cover deterioration from wear and tear or exposure or any defect, which would not have happened if instructions in the owner's manual had been followed. Improper installation, improper assembly or follow-up maintenance along with installation of parts or accessories not originally intended for products of Batca Fitness Systems are also not covered by this warranty. Only genuine Batca parts should be used for replacement, repair, and maintenance for this warranty to apply.

Defective parts will be repaired or replaced at Batca Fitness Systems option, without parts charge to the purchaser. All returns require a return authorization prior to acceptance of repair work. Batca Fitness Systems reserves the right to make design changes without any prior notification and shall not be responsible for incidental or consequential damages.

The purchaser is responsible for shipping the defective part back to the factory. Repair or replacement is the exclusive and sole remedy of the purchaser. Labor charges associated with parts changeovers are not covered by this warranty. Proof of purchase, serial number, model number and date of purchase will be required along with all pertinent information of the alleged damage.

This warranty applies only to the original purchaser and is not transferable. Claims under this warranty must be made directly to Batca Fitness Systems.

Batca Fitness Systems  
1207 N. New Hope Road  
Raleigh, NC 27610  
(919) 255-1233

[www.batcafitness.com](http://www.batcafitness.com)

Please keep this for your records.



Scan the QR Code to  
register your new  
BATCA Product online!

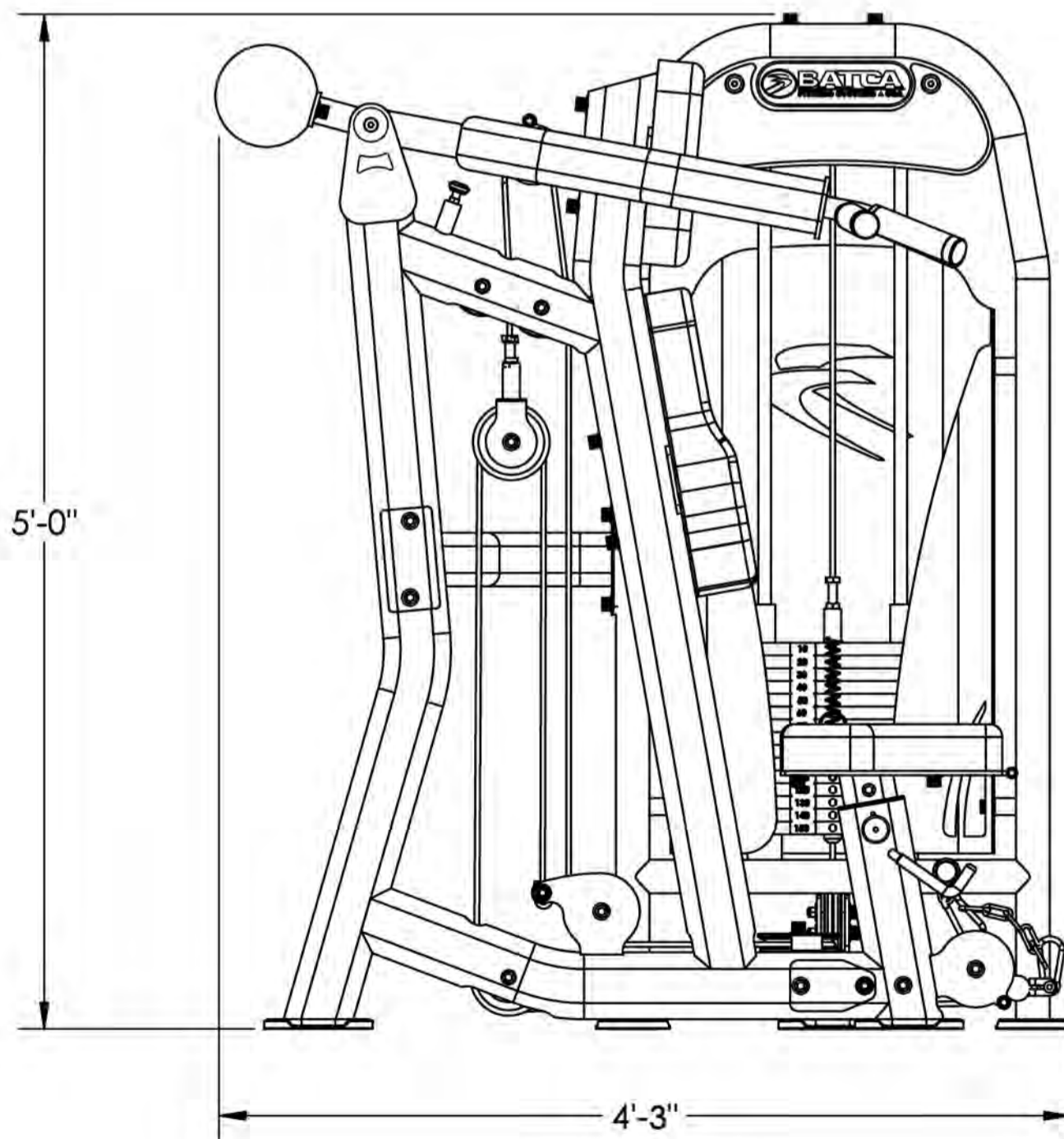
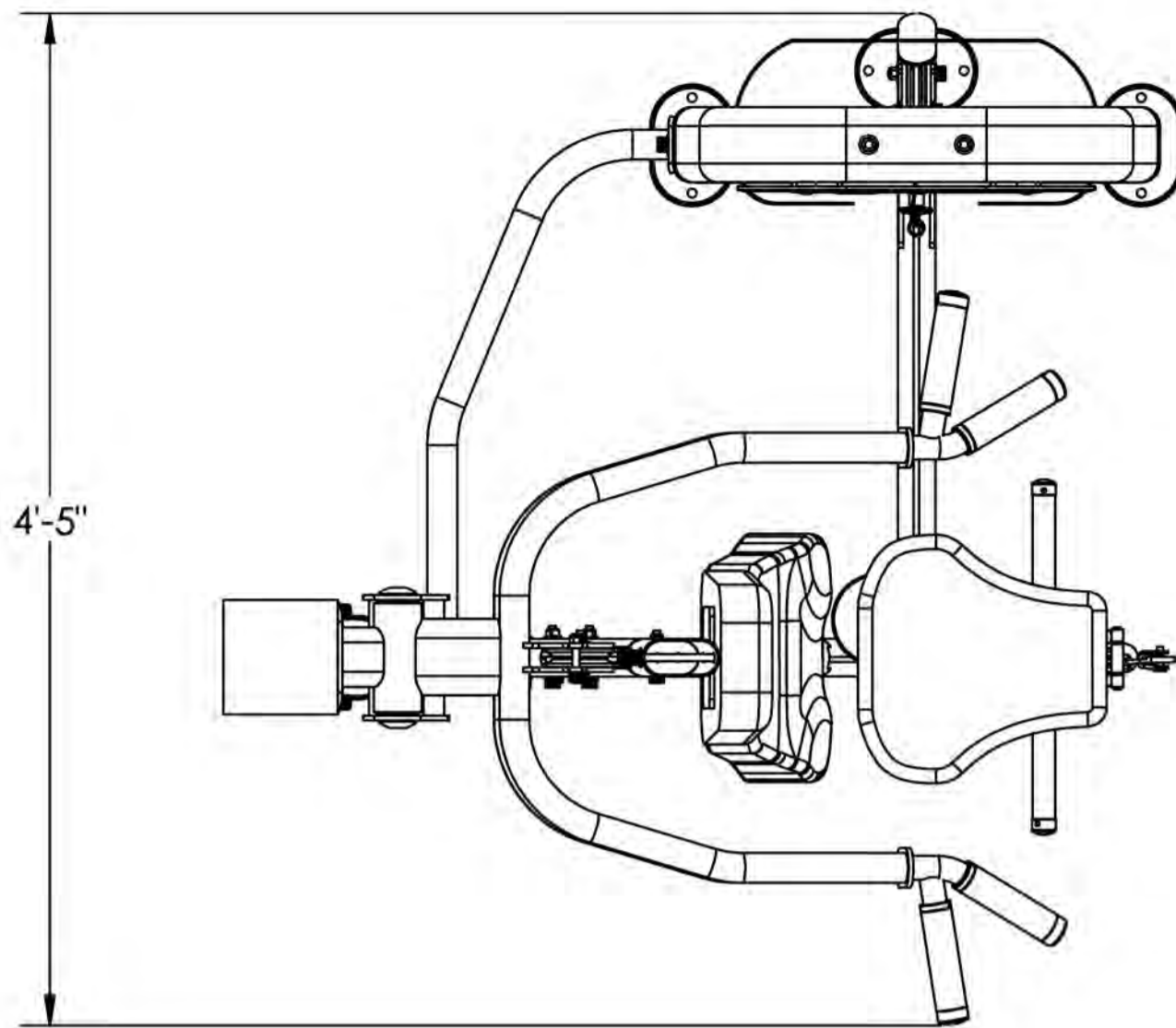

## Layout Diagram

The LD-6 has a layout dimension of 4'-5" (width) x 4'-3" (length) x 5'-" (height). There should be a minimum of 18", preferably 24", of working space around the entire unit.