

Revision 2

January 2006



BATCA
fitness systems · usa

S-1

Pec Fly/ Rear Delt

Owner's Manual



Record Serial Number Here

Date of Purchase

Batca Fitness Systems
Tel. (919) 255-1233
www.batcafitness.com

Instructions

Congratulations on the purchase of your new Batca S-1. This gym will provide you with a lifetime of enjoyment to meet your strength training needs. Batca Fitness Systems strives to build the best quality gyms and to package these gyms in such a way to avoid any damage during shipping.

In order to get started with your assembly you should first familiarize yourself with this manual. It is recommended that you read through each step thoroughly before you begin. Begin by opening your boxes and separating all of your parts. Verify that all parts are accounted for and have no damage. When all parts are accounted for, you may begin your assembly. Some items may have been pre-assembled for your convenience. Please note that hardware quantities shown reflect total quantities for your gym and may not reflect actual quantities in each bag. Assemble your gym on a solid level surface. This will ensure the best possible performance, function, and safety for the gym and your workout.

Assemble your gym according to the step by step instructions found in this manual. Failure to do so will void your warranty and may result in personal injury. After assembly, you should check each station to ensure correct operation. If a problem arises, recheck your assembly with these instructions to verify correct assembly. If you are unable to correct a problem or have questions with your assembly please contact your authorized Batca dealer.

Warning

Batca Fitness Systems has built this gym to give you a safe, effective and enjoyable workout. However, there is a risk assumed by individuals who use this type of equipment. It is very important that all warnings and instructions are read and followed before beginning any exercise program.

It is also very important to read and follow the preventative maintenance schedule described in this manual. If any of the warning labels or stickers are worn, faded, torn, scratched or missing they should be replaced immediately.

WARNING: There is a risk assumed by individuals who use this type of equipment. To minimize risk always follow these rules.

- 1) It is essential that you consult with your physician before beginning any exercise program.
- 2) Inspect equipment before each use for loose, worn, or frayed parts (including cables, nuts and bolts). Replace parts at first signs of wear (use only genuine BATCA replacement parts). Use of equipment that is damaged, worn, frayed or not completely assembled on a solid, level surface may result in injury.
- 3) Make sure all adjustment pins are fully engaged before using equipment.
- 4) Keep all parts of the body and clothing outside the path of any moving parts of the gym. Be alert to the possibility of injury. Do not be careless.
- 5) Minors and children should not be allowed to play on or around this gym.
- 6) If you have any questions on proper use or maintenance of this gym, do not hesitate to call your local BATCA FITNESS SYSTEMS distributor or BATCA FITNESS SYSTEMS at (919) 255-1233. www.batcafitness.com

Table of Contents

	<u>Page</u>		<u>Page</u>
Instructions	2	Final Assembly and Troubleshooting	16
Parts Listing	3	Cable Tension and Adjustments	17
Hardware Comparison	4-7	Maintenance	18
Main Assembly	8-12	Warranty	19
Upholstery	13	Floor Plan Layout	20
Cable Routing	14-15		

Frame Components

ITEM NO.	PART NUMBER	DESCRIPTION	QTY.
1	BFM-10404	Chest Base	1
2	BFM-10403	Chest Pole	1
4	BFM-10430	Weight Plate	19
5	BFM-50633	Guide Rod	2
6	BFM-10413	3/4" 10lb Top Plate	1
7	BFM-50531	Shroud	1
8	BFM-10405	Cage	1
9	BFM-10101	Chest Pivot	1
10	BFM-10110	Chrome Pad Adjustment	1
11	BFM-10132	Foot Assist	1
12	BFM-10138	Chest Press Arm	1
13	BFM-10146	Chest Press Pulley Holder	1
15	BFM-10429	Spacer Tube	2
16	BFM-10137	Foot Shroud	1
18	BFM-50126	Anti-Deflection Plate	1
19	BFM-10426	Cage Top Plate	1
20	BFM-10427	Guide Rod Top Pulley Holder	1
55	BFM-50635	Selector Shaft	1
57	BFM-50246	3/16" Plastic Spacer	2
58	BFM-10133	Free Floater	1

Cables

ITEM NO.	PART NUMBER	DESCRIPTION	QTY.
26	CAB-10401	Foot Assist Cable	2
59	CAB-12012	Weight Stack to Lockout Cable	1
60	CAB-12001	Free Floater to Chest Lockout Cable	1

Tools Required

- 9/16" Wrench
- 3/4" Wrench
- 9/16" Ratchet
- Allen Wrench Set
- Tape Measure

Accessories

ITEM NO.	PART NUMBER	DESCRIPTION	QTY.
31	BFC-50127	Magnetic Weight Stack Pin	1

Upholstery

ITEM NO.	PART NUMBER	DESCRIPTION	QTY.
17	BFU-10118	Bottom Pad	1
21	BFU-10119	Head Pad	1
22	BFU-10120	Back Pad With Lumbar	1

Hardware

ITEM NO.	PART NUMBER	DESCRIPTION	QTY.
3	BFM-50529	Rubber Donut	2
14	BFH-50172	Pillow Block Bearing	2
23	BFH-50255	Rubber Foot	5
24	BFH-50174	4 1/2" Pulley	2
25	BFH-50173	3 1/2" Pulley	2
27	BFH-50234	6 1/2" Extension Spring	2
28	BFH-50149	3/8"-16 Jam Nut (Zinc)	6
29	BFH-50288	3/8"-16 Nylock (Zinc)	4
30	BFH-50253	Beveled Leveler	2
32	BFH-50210	Gas Spring	1
33	BFH-50146	3/8" Flat Washer (Black)	46
34	BFH-50201	1/2" Pulley Spacer	6
35	BFH-50251	1/2" Flat Washer Black	10
36	BFH-50155	1/2"-13 Nylock (Black)	5
37	BFH-50137	HCS 1/2"-13 X 3 1/4" P5	4
37	BFH-50137	HCS 1/2"-13 X 3 1/4" (5/8" Thread)	1
38	BFH-50157	3/8"-16 Nylock (Black)	21
39	BFH-50147	3/8" Lock Washer (Black)	10
40	BFH-50254	HCS 3/8"-16 X 3/4" P5	4
41	BFH-50130	HCS 3/8"-16 X 4 1/4" P5	4
42	BFH-50298	HCS 3/8"-16 X 8 3/4" P5	2
43	BFH-50124	HCS 3/8"-16 X 2 3/4" P5	6
44	BFH-50125	HCS 3/8"-16 X 3" P5	2
45	BFH-50122	HCS 3/8"-16 X 2 1/4" P5	2
46	BFH-50121	HCS 3/8"-16 X 2" P5	3
47	BFH-50119	HCS 3/8"-16 X 1 1/4" P5	2
48	BFH-50129	HCS 3/8"-16 X 4" P5	4
49	BFH-50246	Anti-Skid Material	5
50	BFH-50250	1 1/4" Shoulder Bolt	1
51	BFH-50267	5/16"-18 Nylock (Black)	1
52	BFH-50126	HCS 3/8"-16 X 3 1/4" P5	2
53	BFH-50530	5" Pulley	1
54	BFH-50127	HCS 3/8"-16 X 3 1/2" P5	2
56	BFH-50120	HCS 3/8"-16 X 1 1/2" P5	4
61	BFH-50151	5/16" Flat Washer (Zinc)	4

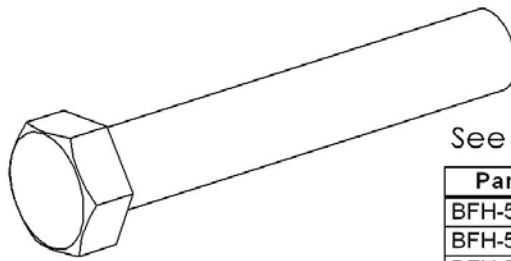
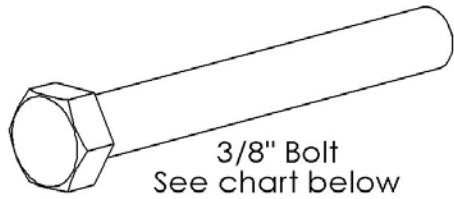

Part #	Size
BFH-50254	3/8" x 3/4"
BFH-50118	3/8" x 1"
BFH-50119	3/8" x 1 1/4"
BFH-50120	3/8" x 1 1/2"
BFH-50285	3/8" x 1 3/4"
BFH-50121	3/8" x 2"
BFH-50122	3/8" x 2 1/4"
BFH-50123	3/8" x 2 1/2"
BFH-50124	3/8" x 2 3/4"
BFH-50125	3/8" x 3"
BFH-50126	3/8" x 3 1/4"
BFH-50127	3/8" x 3 1/2"
BFH-50128	3/8" x 3 3/4"
BFH-50129	3/8" x 4"
BFH-50130	3/8" x 4 1/4"
BFH-50131	3/8" x 4 1/2"
BFH-50274	3/8" x 4 3/4"
BFH-50279	3/8" x 5"
BFH-50270	3/8" x 5 1/4"
BFH-50132	3/8" x 5 1/2"
BFH-50133	3/8" x 6 1/2"
BFH-50298	3/8" x 8 3/4"
BFH-50134	3/8" x 9"

Part #	Size
BFH-50135	1/2" x 2 3/4"
BFH-50136	1/2" x 3"
BFH-50137	1/2" x 3 1/4"
BFH-50138	1/2" x 3 1/2"
BFH-50139	1/2" x 4 1/4"
BFH-50140	1/2" x 4 1/2"
BFH-50141	1/2" x 5 1/2"

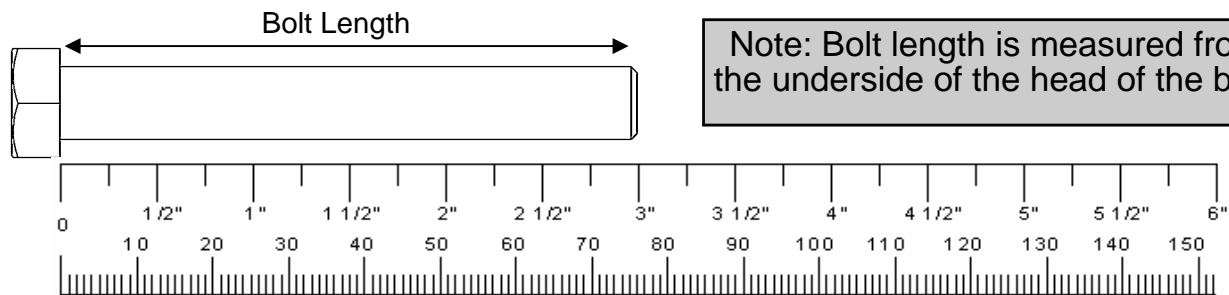
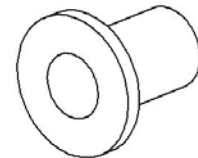
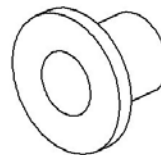
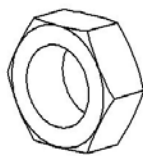
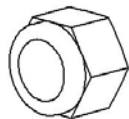
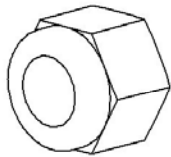
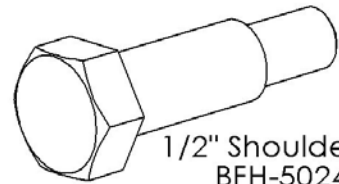
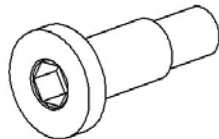
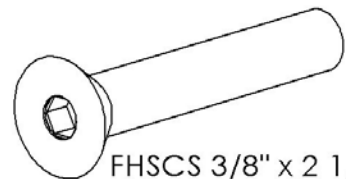
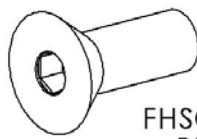

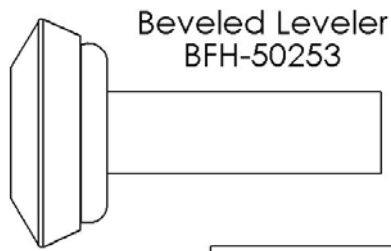

Beveled Level
BFH-50253

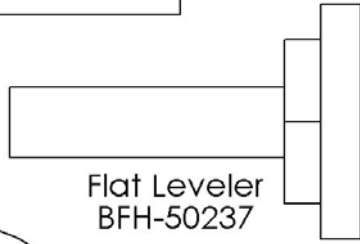

Flat Level
BFH-50237

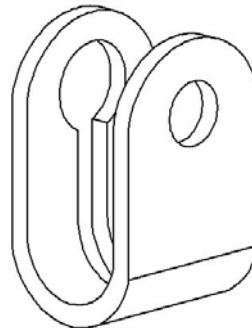

Cable Strap
BFH-50227

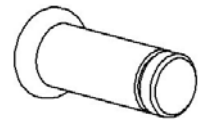

Pin
BFH-50238



Snap Ring
BFH-50239

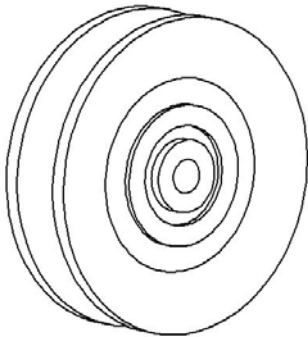

3 1/2" Pulley
BFH-50173

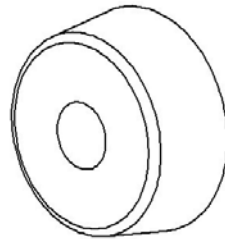

Rubber Donut
BFH-50190

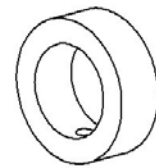

Threaded Collar
BFH-50220

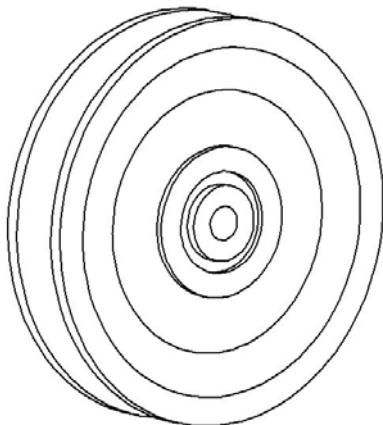

4 1/2" Pulley
BFH-50174

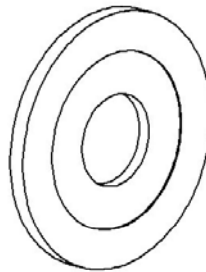

3" Plastic Washer
BFH-50221



Plastic Collar
BFH-252

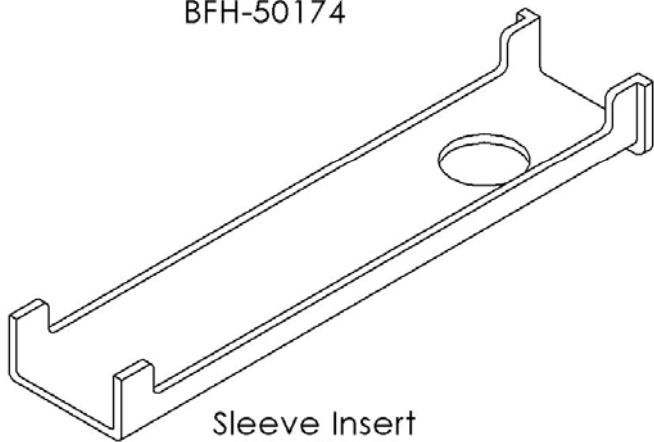

Sleeve Insert
BFH-50175

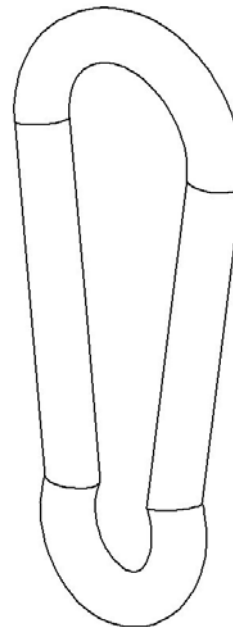

Snap Hook
BFH-50188

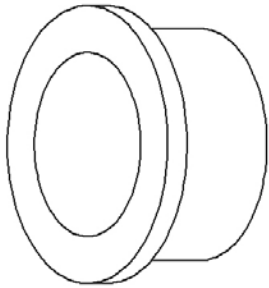

1" Bronze Bushing
BFH-50101

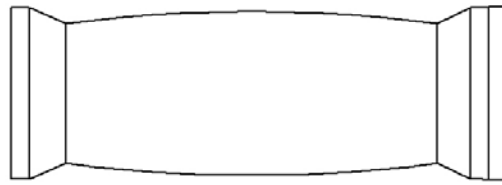

Molded Grip - BFH-50110

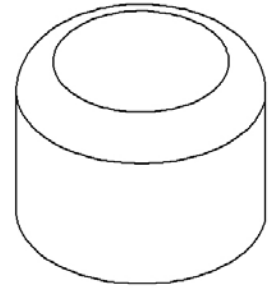

1" Outer Plastic Cap
BFH-50111

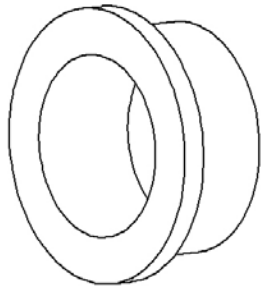

1" Bronze Bushing x 1/2 L
BFH-50297

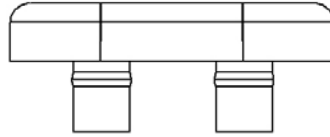

BFH-50222

Rubber Bumpers

BFH-50200

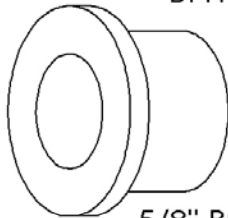
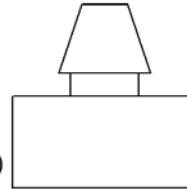

5/8" Bronze Bushing
BFH-50102

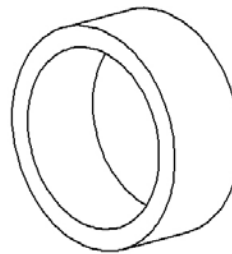

5/8" Spacer
BFM-50247

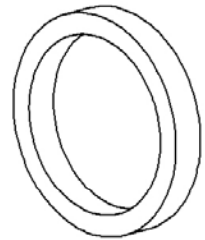

3/16" Spacer
BFM-50246

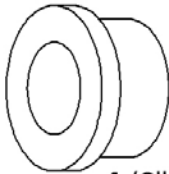

1/2" Bronze Bushing
BFH-50103

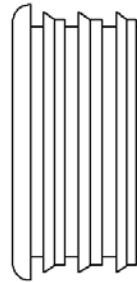

1 1/2" Inner Plastic Cap
BFH-50114



Cable Pivot Bushing
BFH-50248

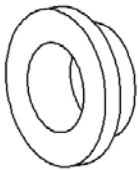

Short 1/2" Bushing
BFH-50244

1" Inner Plastic Cap
BFH-50280

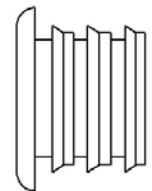

1/2" Snap Ring
BFH-50166

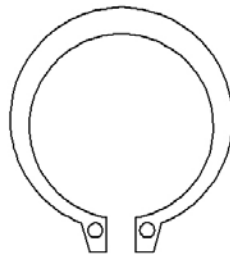

1" Snap Ring
BFH-50165

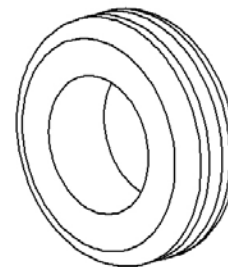

Rubber Grommet
BFH-50199

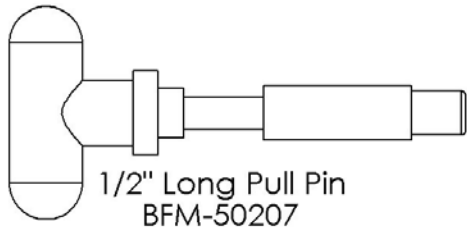

1/2" Long Pull Pin
BFM-50207

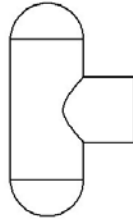

Pull Pin T-Handle
BFM-50263

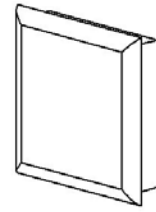

Plastic Cap

Part #	Size
BFH-50211	2" x 2"
BFH-50212	2" x 3"
BFH-50213	1 1/2" x 2"
BFH-50214	1 3/4" x 1 3/4"
BFH-50215	1 1/2" x 1 1/2"

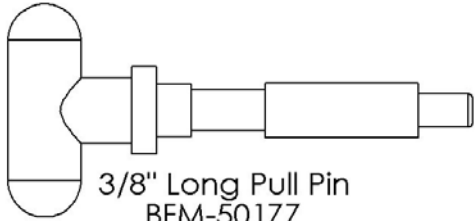

3/8" Long Pull Pin
BFM-50177

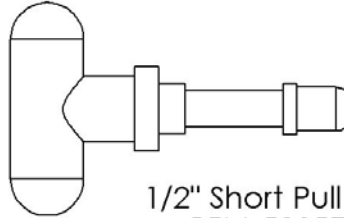

1/2" Short Pull Pin
BFM-50157

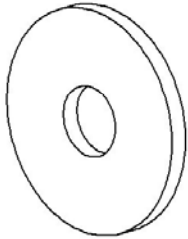

3/8" Fender Washer
BFH-50242



3/8" Flat Washer
BFH-50146



1/2" Flat Washer
BFH-50251

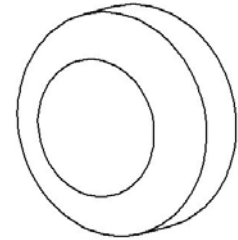

Screw Cap Cover
BFH-50112

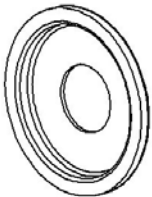

Screw Cap Washer
BFH-50113



3/8" Lock Washer
BFH-50147

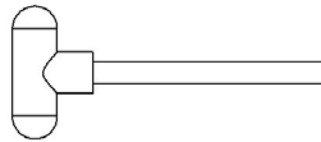

Weight Stack Pin
BFC-50127

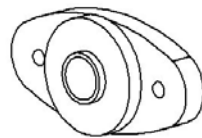

Side Mounted
Flange Bearing
BFH-50171

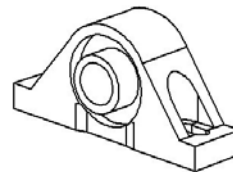

Pillow Block Bearing
BFH-50172

Items not shown.

Part #	Description
BFH-50259	Midnight Black Paint
BFH-50278	Silver Metallic Paint
BFH-50198	Large Logo
BFH-50197	Small Logo
BFH-50236	Foam Grip
BFH-50246	Anti Skid
BFH-50262	Silicon Gel Pack
BFC-10101	1 inch chain
BFC-10102	12 inch chain

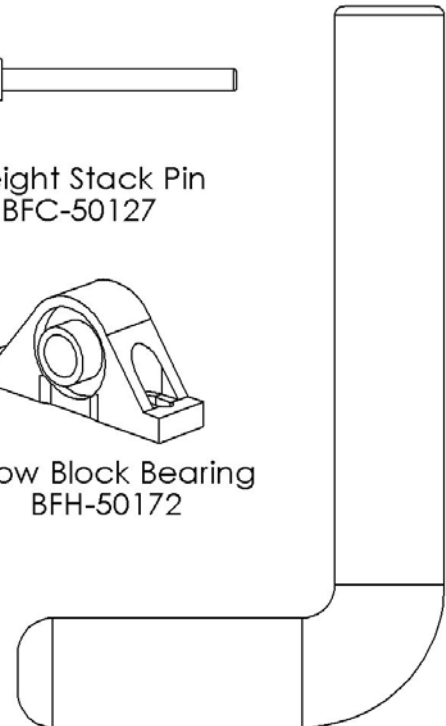

Bar Catch Rubber Sleeve
BFH-50240



PLEASE FOLLOW ALL DIRECTIONS VERY CAREFULLY FOR PROPER INSTALLATION.

Step 1:



Note: For a more consistent appearance, position all bolts in the direction shown in each figure.

- All Flat Washers and Nylocks are 3/8" unless otherwise noted.

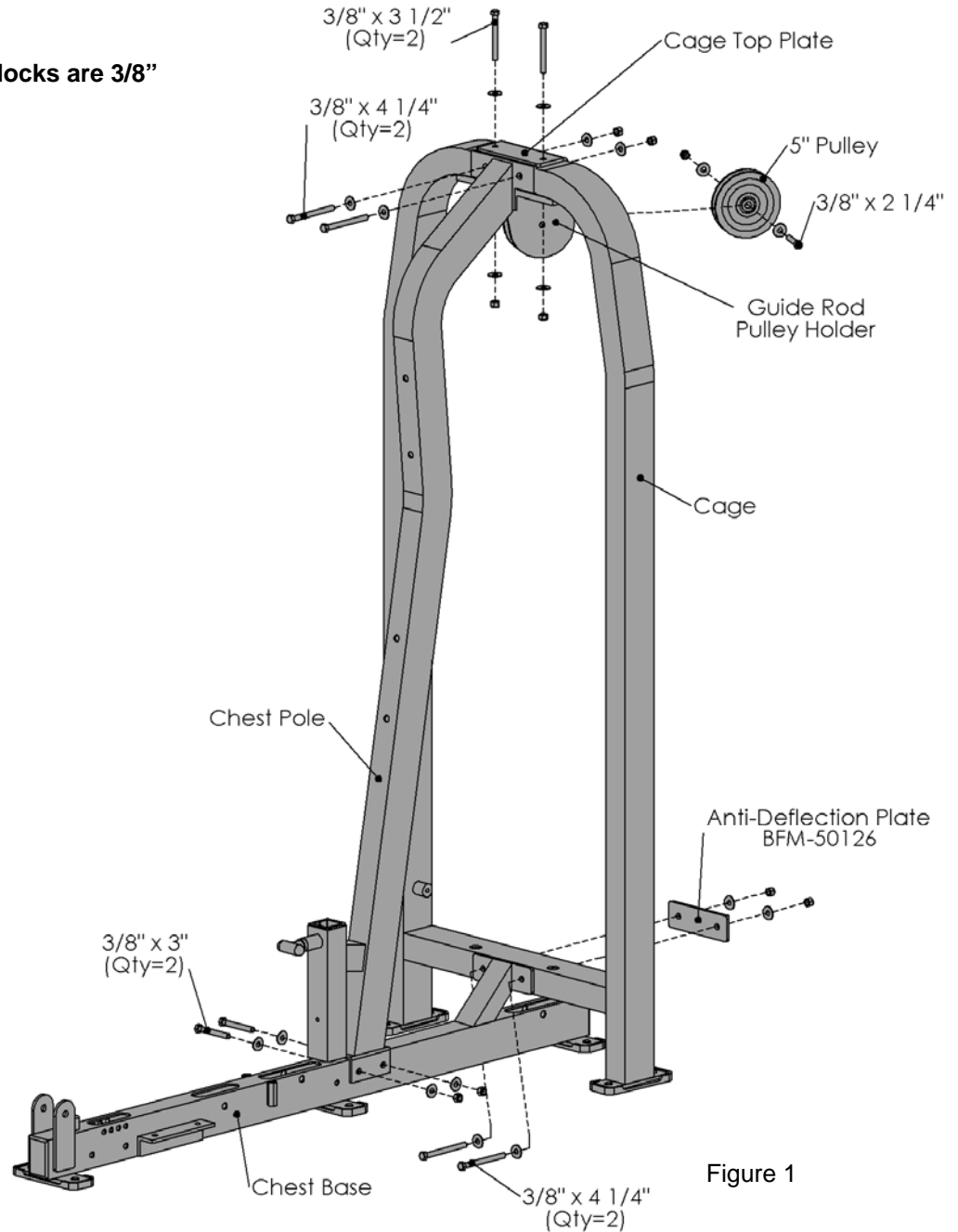

Figure 1

Item #	Part #	Description	Qty
1	BFM-10404	Chest Base	1
2	BFM-10403	Chest Pole	1
8	BFM-10405	Cage	1
18	BFM-50126	Anti-Deflection Plate	1
19	BFM-10426	Cage Top Plate	1
20	BFM-10427	Guide Rod Top Pulley Holder	1
23	BFM-50255	Rubber Foot	5

Item #	Part #	Description	Qty
33	BFH-50146	3/8" Flat Washer (Black)	18
38	BFH-50157	3/8"-16 Nylock (Black)	9
41	BFH-50130	HCS 3/8"-16 x 4 1/4" P5	4
44	BFH-50125	HCS 3/8"-16 x 3" P5	2
45	BFH-50122	HCS 3/8"-16 x 2 1/4" P5	1
53	BFH-50530	5" Pulley	1
54	BFH-50127	HCS 3/8"-16 x 3 1/2" P5	2

Step 2:

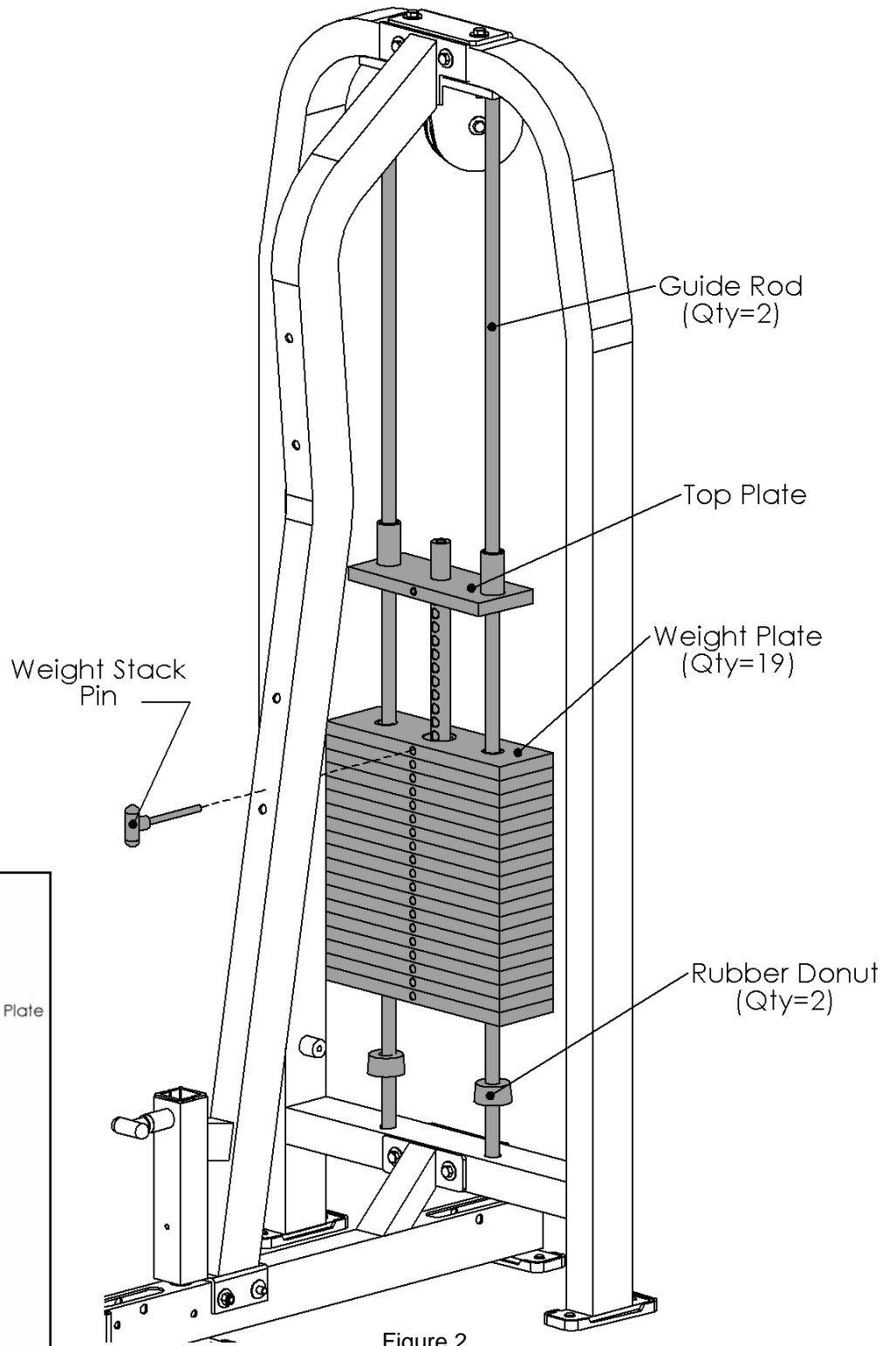

Figure 2

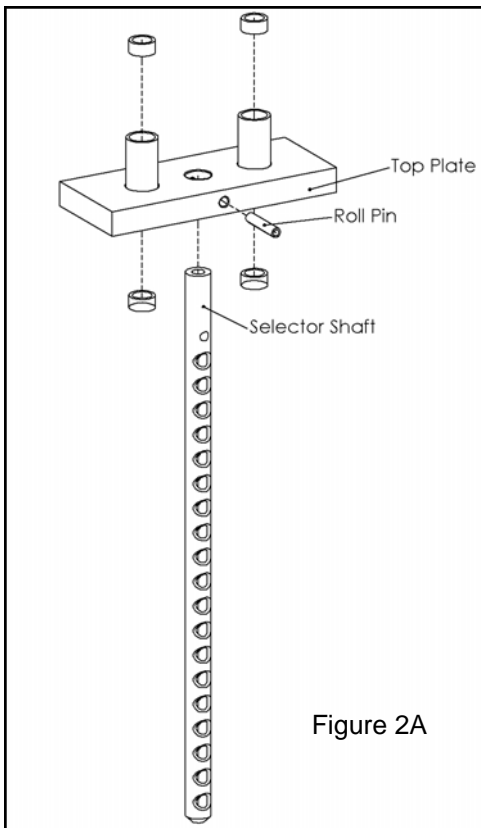

Figure 2A

All Flat Washers and Nylocks are 3/8" unless otherwise noted.

Item #	Part #	Description	Qty
3	BFM-50529	Rubber Donut	2
4	BFM-10430	Weight Plate	19
5	BFM-50633	Guide Rod	2
6	BFM-10413	3/4" 10lb Top Plate	1
31	BFC-50127	Magnetic Weight Stack Pin	1
55	BFM-50635	Selector Shaft	1

Step 3:

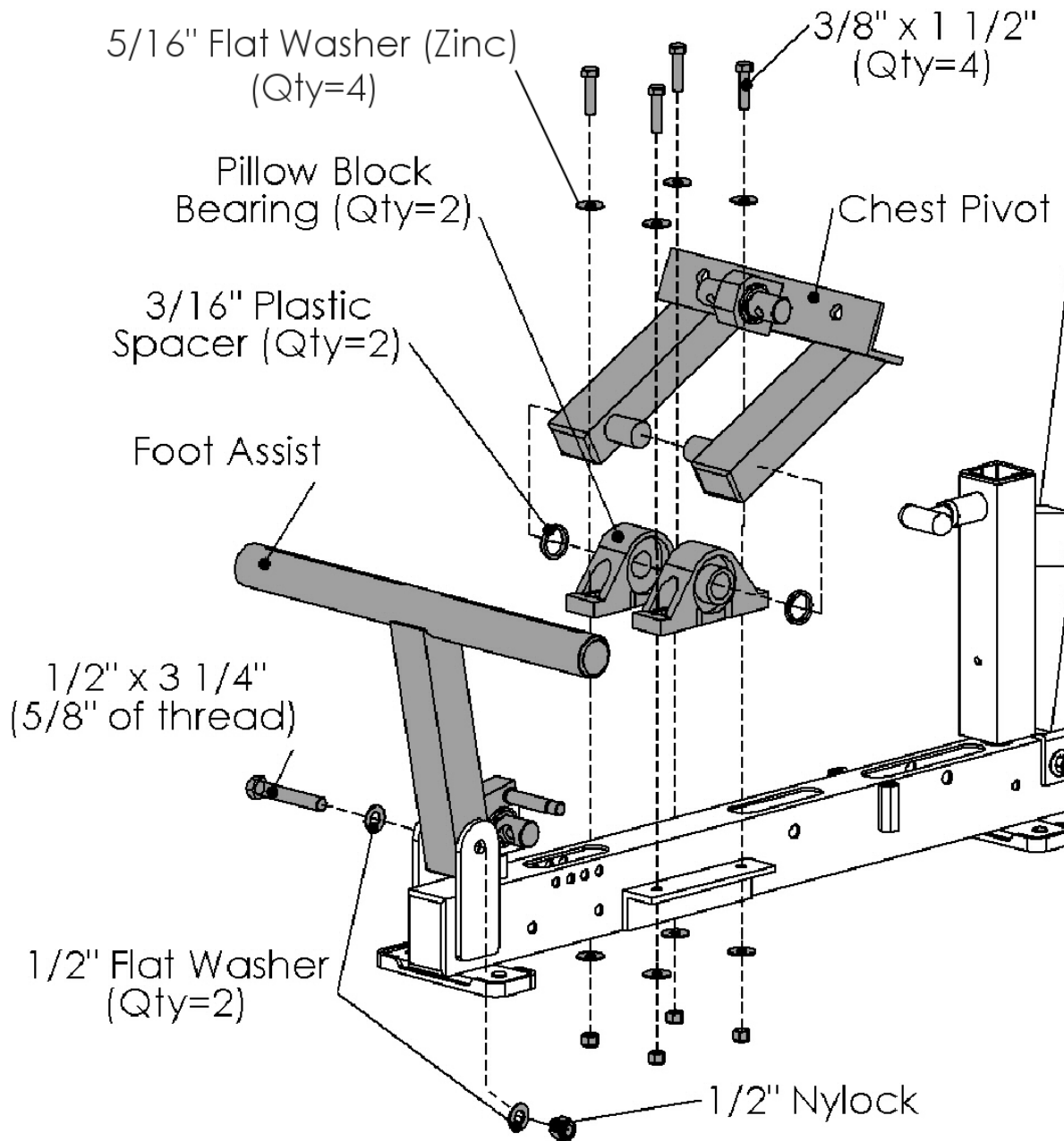

Figure 3

Item #	Part #	Description	Qty
9	BFM-10101	Chest Pivot	1
11	BFM-10132	Foot Assist	1
14	BFH-50172	Pillow Block Bearing	2
33	BFH-50146	3/8" Flat Washer (Black)	4
35	BFH-50251	1/2" Flat Washer (Black)	2
36	BFH-50155	1/2"-13 Nylock (Black)	1
37	BFH-50137	HCS 1/2"-13 x 3 1/4 (5/8" Thread)	1
38	BFH-50157	3/8"-16 Nylock (Black)	4
56	BFH-50120	HCS 3/8"-16 x 1 1/2" P5	4
57	BFM-50246	3/16" Plastic Spacer	2
61	BFH-50151	5/16" Flat Washer (Zinc)	4

All Flat Washers and Nylocks are 3/8" unless otherwise noted.

Step 4:

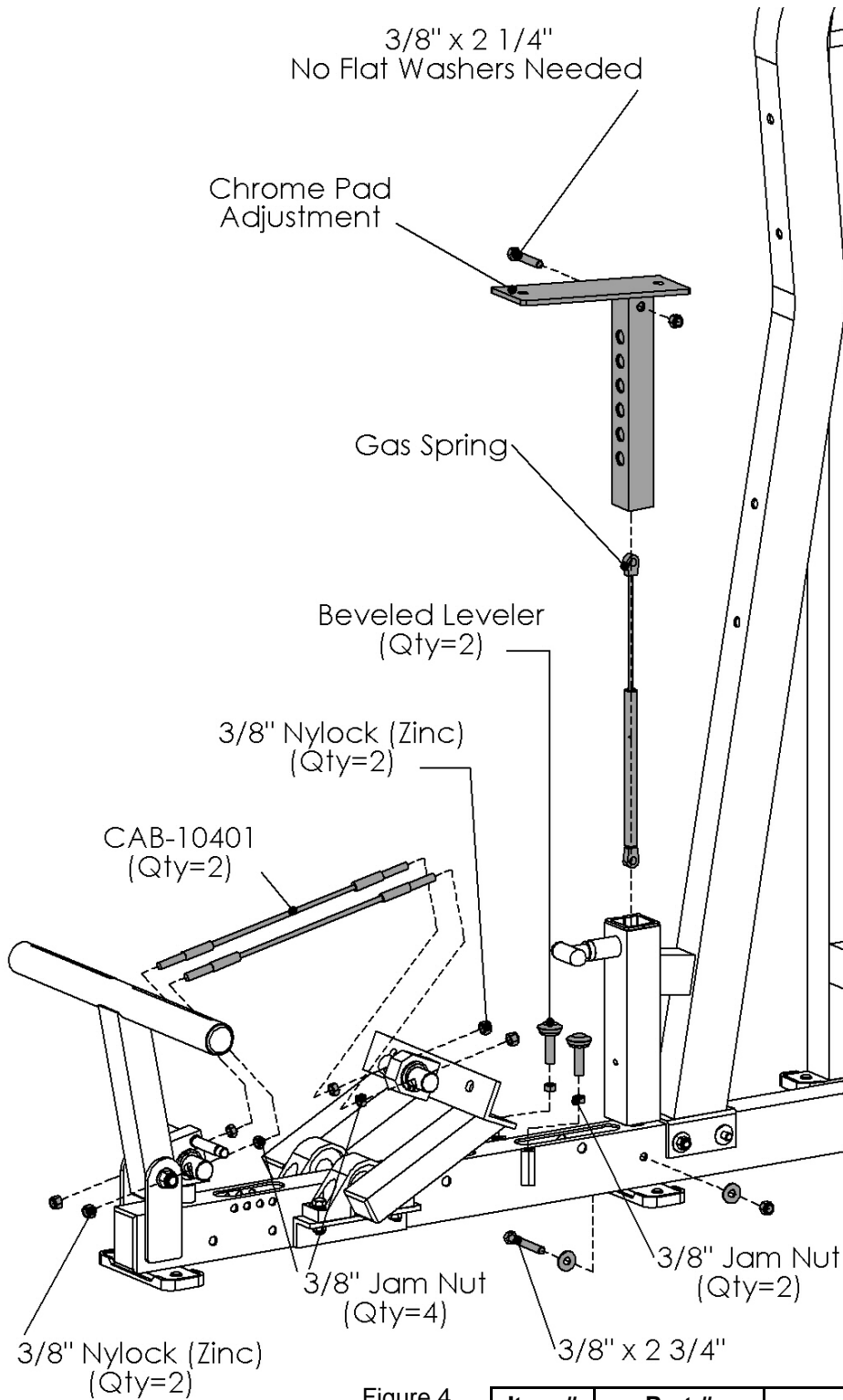
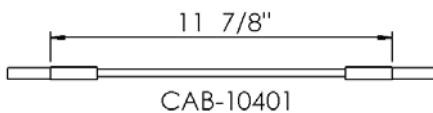

Figure 4



Item #	Part #	Description	Qty
10	BFM-10110	Chrome Pad Adjustment	1
26	CAB-10401	Foot Assist Cable	2
28	BFH-50149	3/8"-16 Jam Nut (Zinc)	6
29	BFH-50288	3/8"-16 Nylock (Zinc)	4
30	BFH-50253	Beveled Leveler	2
32	BFH-50210	Gas Spring	1
33	BFH-50146	3/8" Flat Washer (Black)	2
38	BFH-50157	3/8"-16 Nylock (Black)	2
43	BFH-50124	HCS 3/8"-16 x 2 3/4" P5	1
45	BFH-50122	HCS 3/8"-16 x 2 1/4" P5	1

All Flat Washers and Nylocks are 3/8" unless otherwise noted.

Step 5:

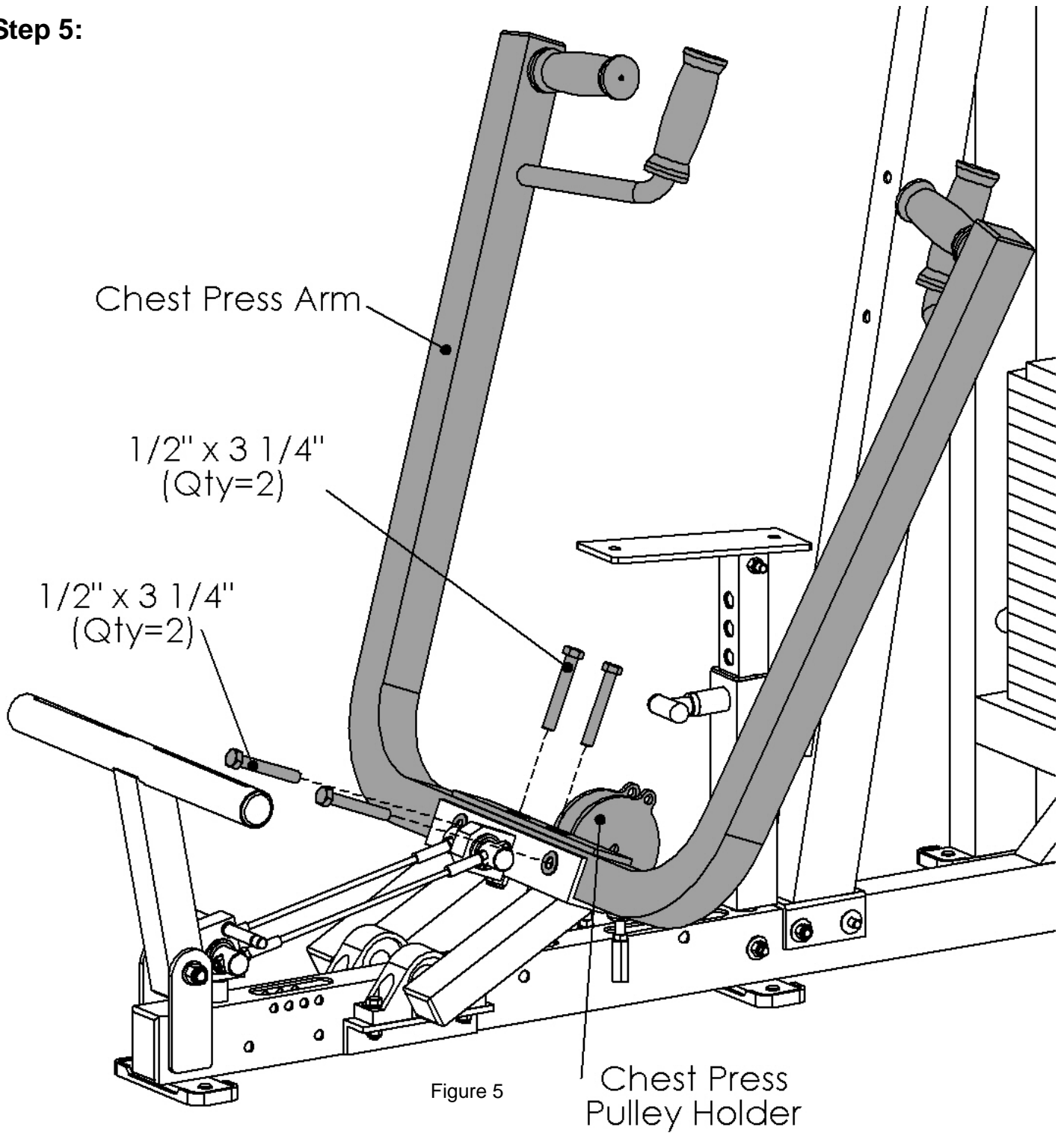

Figure 5

Note: All bolts in this step receive two 1/2" Flat Washers and one 1/2" Nylock.

Item #	Part #	Description	Qty
12	BFM-10138	Chest Press Arm	1
13	BFM-10146	Chest Press Pulley Holder	1
35	BFH-50251	1/2" Flat Washer (Black)	8
36	BFH-50155	1/2"-13 Nylock (Black)	4
37	BFH-50137	HCS 1/2"-13 x 3 1/4 P5	4

All Flat Washers and Nylocks are 3/8" unless otherwise noted.

Step 6:

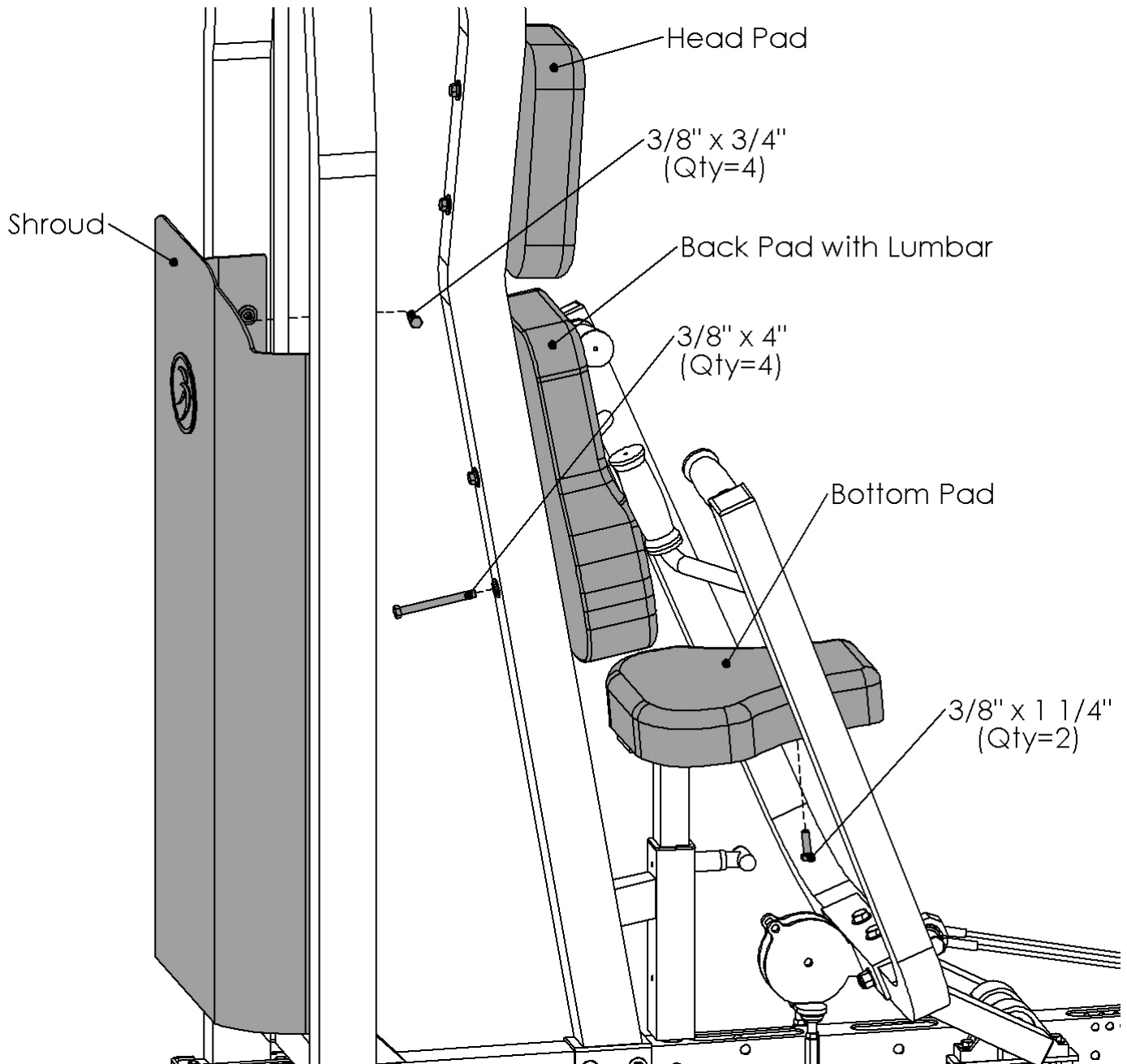

Figure 6

Note: All bolts in this step receive one 3/8" Flat Washer and one 3/8" Lock Washer instead of one 3/8" Nylock.

Item #	Part #	Description	Qty
7	BFM-50531	Shroud	1
17	BFU-10118	Bottom Pad	1
21	BFU-10119	Head Pad	1
22	BFU-10120	Back Pad with Lumbar	1
33	BFH-50146	3/8" Flat Washer (Black)	10
39	BFH-50147	3/8" Lock Washer (Black)	10
40	BFH-50254	HCS 3/8"-16 x 3/4" P5	4
47	BFH-50119	HCS 3/8"-16 x 1 1/4" P5	2
48	BFH-50129	HCS 3/8"-16 x 4" P5	4

All Flat Washers and Nylocks are 3/8" unless otherwise noted.

Step 7:

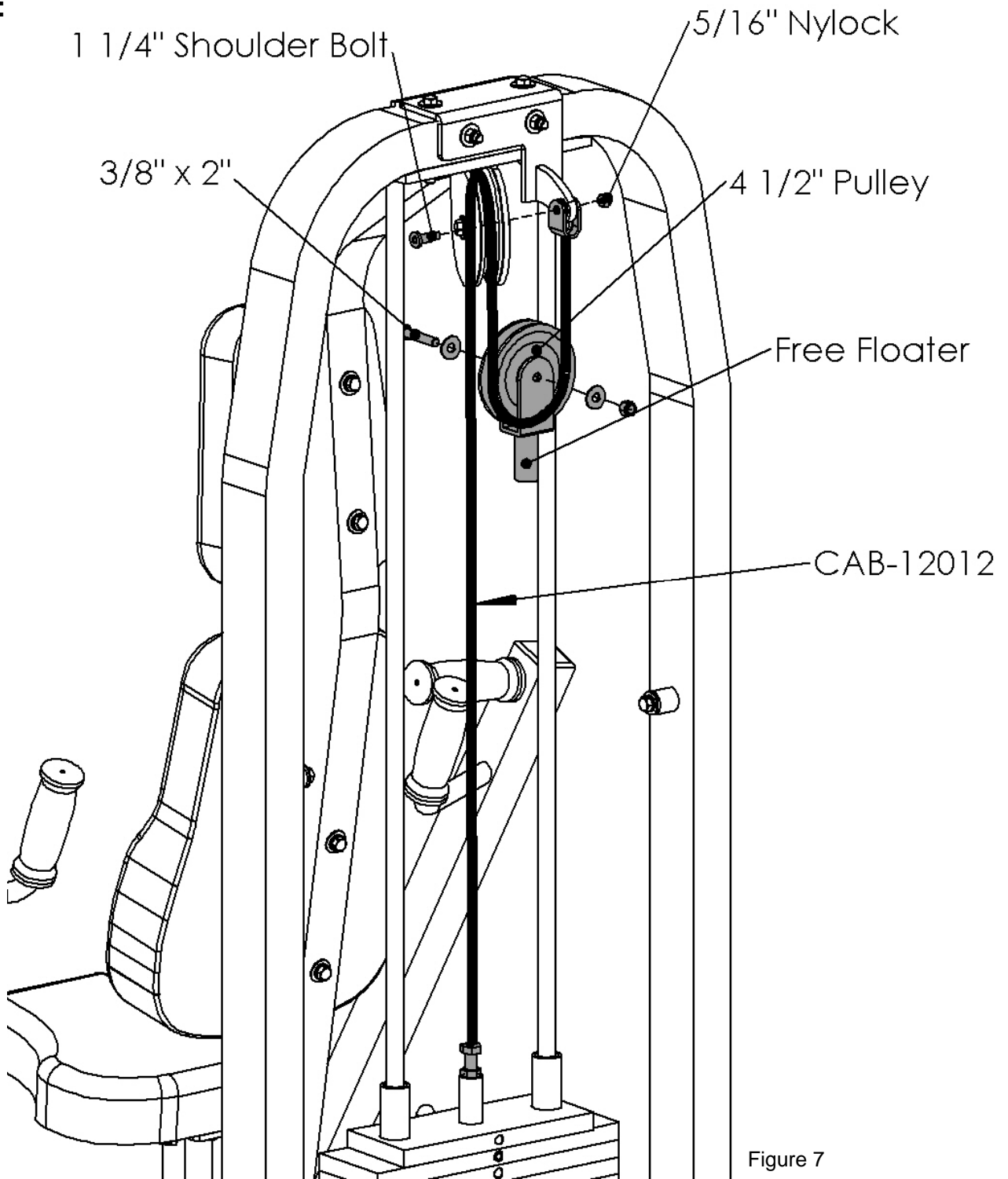
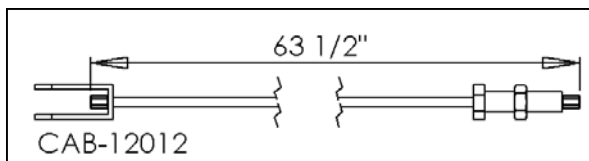

Figure 7

Note: Shroud was removed from drawing for clear view of cable.



All Flat Washers and Nylocks are 3/8" unless otherwise noted.

Item #	Part #	Description	Qty
24	BFH-50174	4 1/2" Pulley	1
33	BFH-50146	3/8" Flat Washer (Black)	2
38	BFH-50157	3/8"-16 Nylock (Black)	1
46	BFH-50121	HCS 3/8"-16 x 2" P5	1
50	BFH-50250	1 1/4" Shoulder Bolt	1
51	BFH-50267	5/16"-18 Nylock	1
58	BFM-10133	Free Floater	1
59	CAB-12012	Weight Stack to Lockout Cable	1

Step 8:

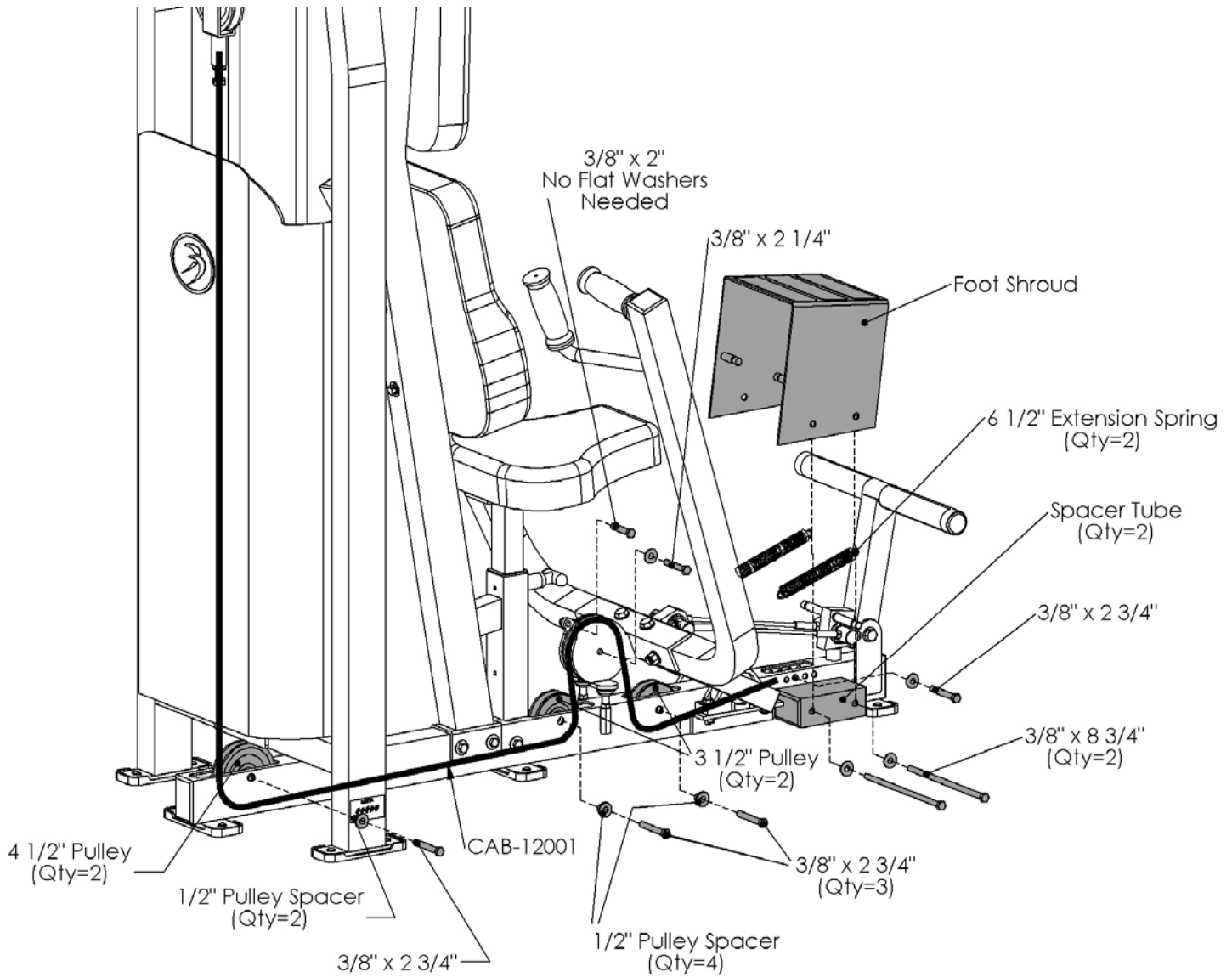
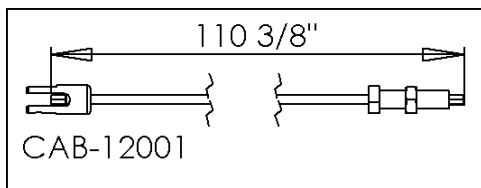

Figure 8



Item #	Part #	Description	Qty
15	BFM-10429	Spacer Tube	2
16	BFM-10137	Foot Shroud	1
24	BFH-50174	4 1/2" Pulley	2
25	BFH-50173	3 1/2" Pulley	2
27	BFH-50234	6 1/2" Extension Spring	2
33	BFH-50146	3/8" Flat Washer (Black)	10
34	BFH-50201	1/2" Pulley Spacer	6
38	BFH-50157	3/8"-16 Nylock (Black)	9
42	BFH-50298	HCS 3/8"-16 x 8 3/4" P5	2
43	BFH-50124	HCS 3/8"-16 x 2 3/4" P5	5
45	BFH-50122	HCS 3/8"-16 x 2 1/4" P5	1
46	BFH-50121	HCS 3/8"-16 x 2" P5	1
60	CAB-12001	Free Floater to Chest Lockout Cable	1

All Flat Washers and Nylocks are 3/8" unless otherwise noted.

Final Assembly and Troubleshooting

Weight Stack Decals:

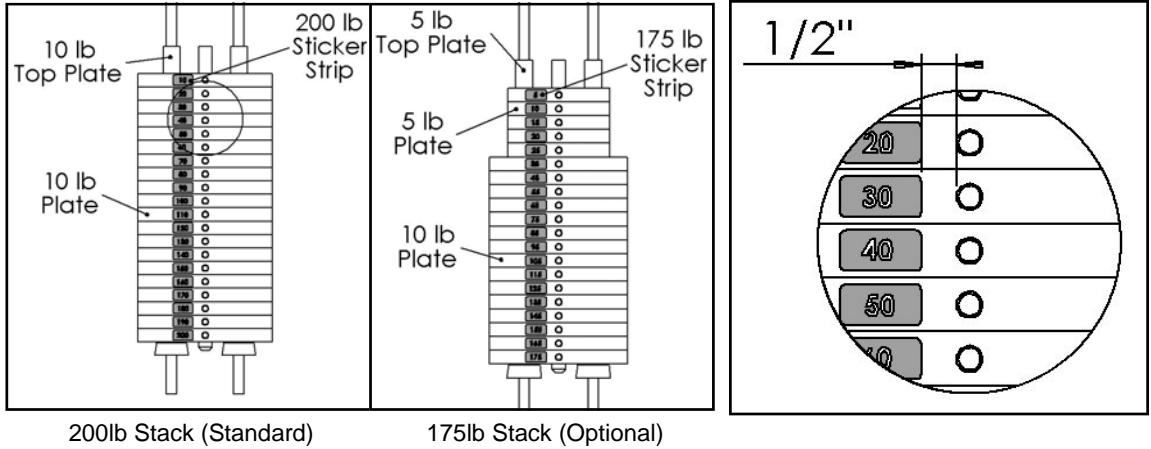

IMPORTANT - Check These Components Before Using Gym:

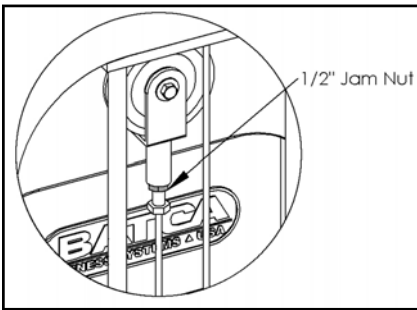

Free Floater

- Each Cable with a threaded bolt on either end **must be threaded at least 1/2"** into its attachment, whether it be a Free Floater, Lockout Free Floater, or the Top Plate of the weight stack. Each must also be secured with a 1/2" Jam Nut to ensure a safe and proper connection.

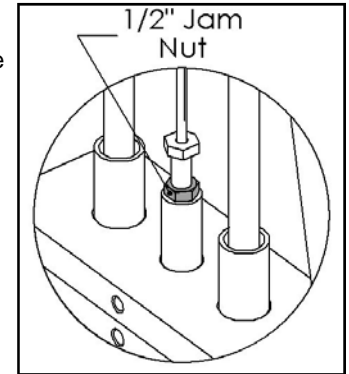

Top Plate

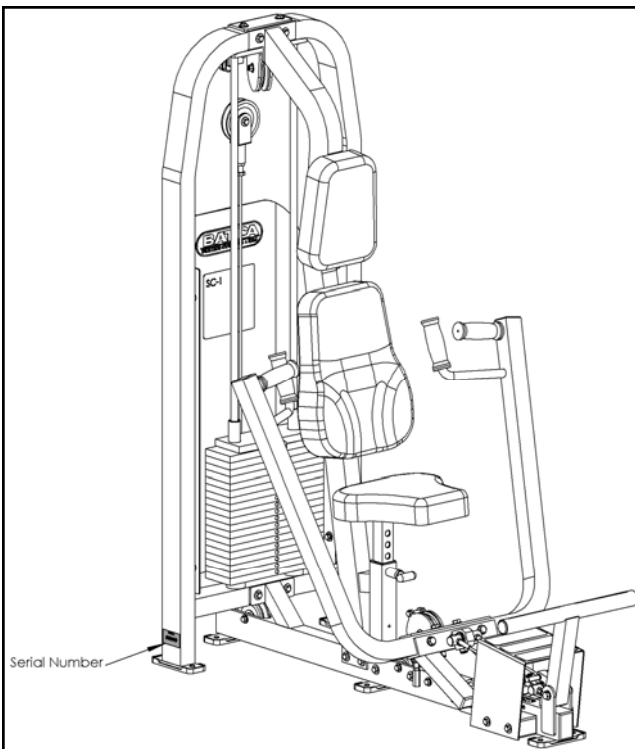

- **Wrench Tighten** the two set screws on all Pillow Block Bearings with an Allen Wrench.

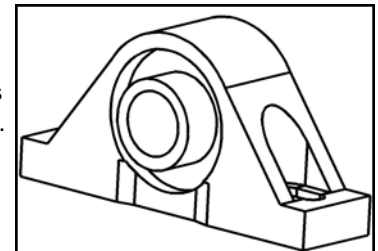

Pillow Block Bearing
BFH-50172

- **Record** your serial number on the front of this manual and keep for your records. The serial number can be found on the side of the cage as seen in the figure to the left..

Cable Adjustments

- **Adjust** cables to proper tension from any of the locations shown below.



Note: All cables with threaded adjustable ends must have at least 1/2" of the threads threaded in to its counterpart. It is very important that the 1/2" Jam Nut be wrench tightened to the counterpart to ensure that the threaded adjustable end of the cable does not back out of its counterpart.

- **Note:** If the top plate raises off of the second plate in the weight stack, then the cable tension is too tight. You will need to take some of the tension out to lower the Top plate flush with the second plate.

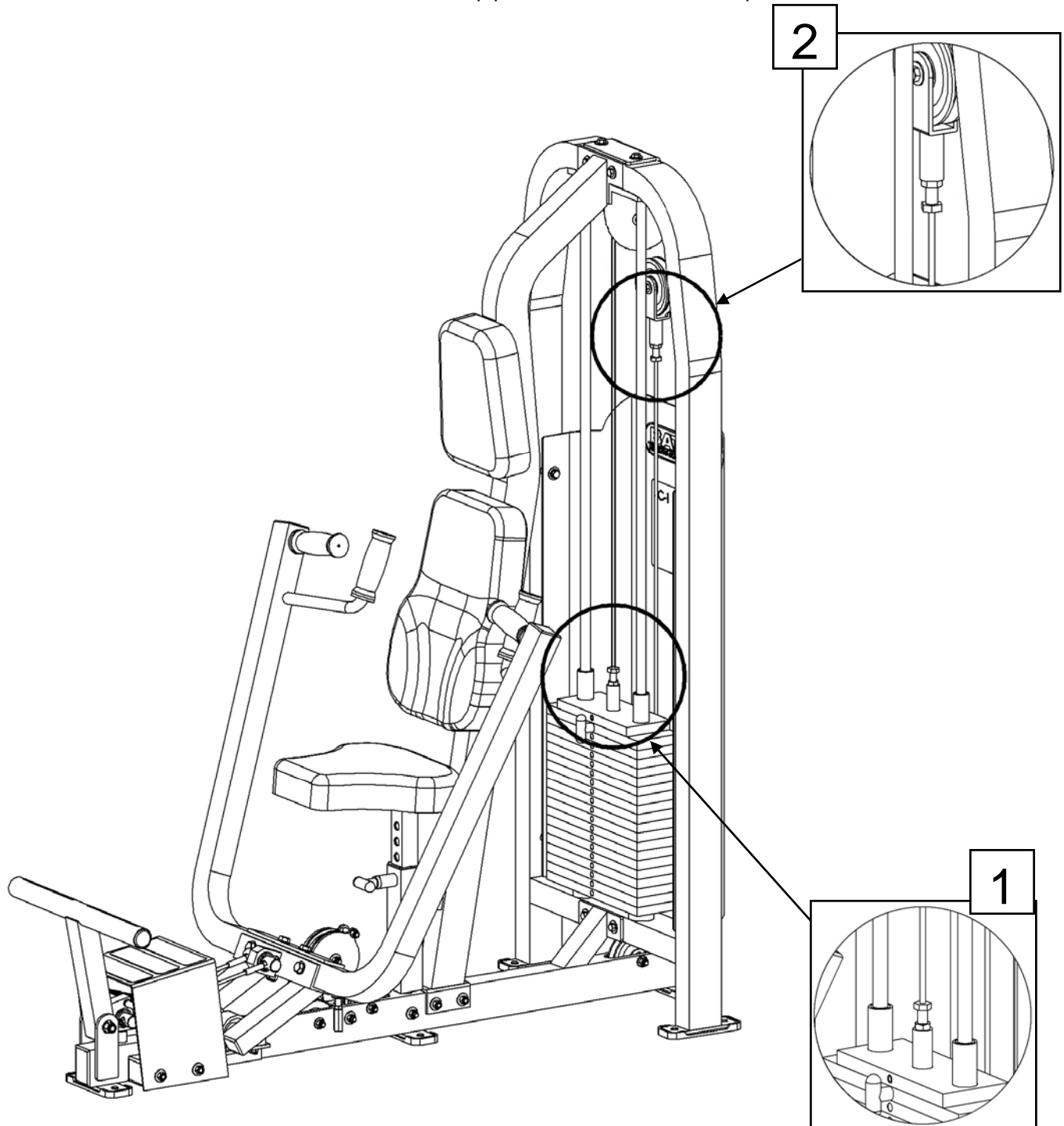

Preventive Maintenance

Batca Fitness Systems strives to give you the very best in quality, performance and safety through carefully engineered designs and excellent workmanship. In order to maintain this high level of quality the preventative maintenance schedule below should be followed.

Clean upholstery, grips, and roller pads with mild soap and water generally after every use. The guide rods, chrome slides and frame should be cleaned with a cotton cloth. Upon cleaning the guide rods, a thin layer of Silicone or Teflon gel should be applied to each rod to ensure a glass smooth performance.

An overall inspection should be done before each workout. If the warning and safety decals are worn or have been removed they should be replaced immediately. The cables and cable systems should be inspected for signs of wear and proper tension. In order to check cables properly you should carefully run the cable through your fingertips, checking for signs of wear, cracks, burs and thinning spots. Replace any part at first signs of wear. Cables should be adjusted for proper tension. See assembly instructions for this detail. All hardware, stops, and adjustments should be checked and tightened as required.

The guide rods on your machine should be cleaned and lubricated regularly. This will ensure a glass smooth performance from your weight stack. A thin layer of either Silicone or Teflon gel should applied to each rod. Each pillow block bearing and flange bearing has a grease fittings that must be lubricated regularly. Use general purpose bearing grease and follow the schedule below.

Although cables should be inspected daily, it is important that ALL cables be replaced as directed in the schedule below. Please note that at any first sign of wear the cable should be replaced immediately.

If there are any questions concerning maintenance, please contact your local Batca dealer or contact Batca Fitness Systems directly at:

Batca Fitness Systems
(919) 255-1233
www.batcafitness.com

	Daily		Weekly		Monthly		Quarterly		Years	
	Commercial	Home	Commercial	Home	Commercial	Home	Commercial	Home	Commercial	Home
Clean										
Upholstery	X			X						
Hand Grips	X			X						
Roller Pads	X			X						
Guide Rods			X			X				
Chrome Slides			X			X				
Frame			X			X				
Inspect										
Overall	X	X								
Safety Decals	X	X								
Cables	X	X								
Cable Tension			X			X				
Pulleys	X	X								
Hardware	X	X								
Stops	X	X								
Upholstery	X	X								
Hand Grips			X			X				
Frame			X			X				
Bushings	X			X						
Bearings	X			X						
Lubricate										
Guide Rods			X			X				
Bearings							As Needed			1
Replace										
Cables									1	3

Limited Lifetime Warranty

What is covered

For Residential Use:

Batca Fitness Systems warrants all of its products against defects in manufacturing, materials and workmanship under normal use and service for one year from date of purchase including paint, chrome, upholstery and grips. Batca Fitness Systems also warrants all cables, belts, bolts, nuts, caps, plugs, bumpers, washers, levelers, decals, gas springs and other hardware for three years after date of purchase; all moving parts, including pulleys, bushings, bearings and pull pins for five years after date of purchase and warrants the frame and all welded parts for the lifetime of the original purchaser.

For Commercial Use:

Batca Fitness Systems warrants all of its products against defects in manufacturing, materials and workmanship under normal use and service for six months from date of purchase including paint, chrome, upholstery and grips. Batca Fitness Systems also warrants all cables, belts, bolts, nuts, caps, plugs, bumpers, washers, levelers, decals, gas springs and other hardware for one year after date of purchase; all moving parts, including pulleys, bushings, bearings and pull pins for three years after date of purchase and warrants the frame and all welded parts for ten years after date of purchase.

What is not covered

This warranty does not cover damage, which results from shipping, misuse, abuse, neglect, carelessness, modification or alteration, accident, fire, flood, "acts of God" or other contingencies beyond the control of Batca Fitness Systems. This warranty also does not cover deterioration from wear and tear or exposure or any defect, which would not have happened if instructions in the owner's manual had been followed. Improper installation, improper assembly or follow-up maintenance along with installation of parts or accessories not originally intended for products of Batca Fitness Systems are also not covered by this warranty. Only genuine Batca parts should be used for replacement, repair, and maintenance for this warranty to apply.

Defective parts will be repaired or replaced at Batca Fitness Systems option, without parts charge to the purchaser. All returns require a return authorization prior to acceptance of repair work. Batca Fitness Systems reserves the right to make design changes without any prior notification and shall not be responsible for incidental or consequential damages.

The purchaser is responsible for shipping the defective part back to the factory. Repair or replacement is the exclusive and sole remedy of the purchaser. Labor charges associated with parts changeovers are not covered by this warranty. Proof of purchase, serial number, model number and date of purchase will be required along with all pertinent information of the alleged damage.

This warranty applies only to the original purchaser and is not transferable. Claims under this warranty must be made directly to Batca Fitness Systems.

Batca Fitness Systems
1207 N. New Hope Road
Raleigh, NC 27610
(919) 255-1233

www.batcafitness.com

Please keep this for your records.

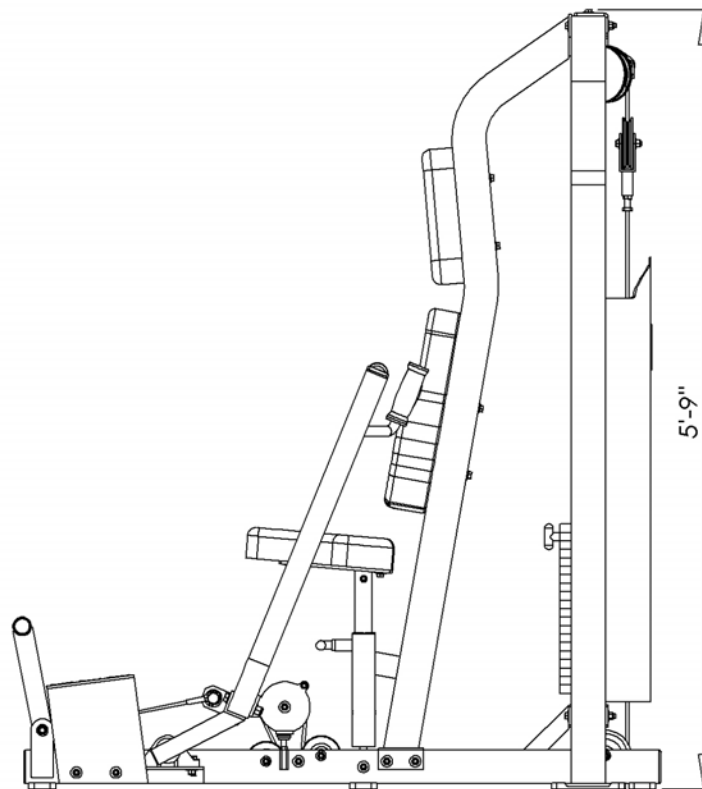
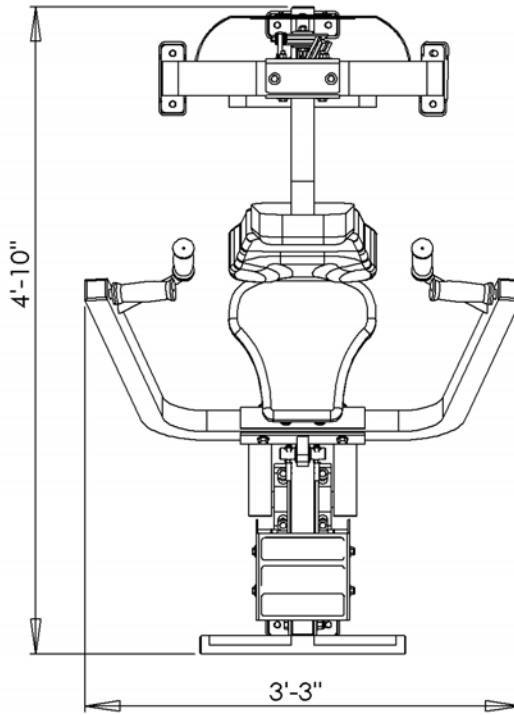

Layout Diagram

The S-1 has a layout dimension of 3'-3" (width) x 4'-10" (length) x 5'-9" (height). There should be a minimum of 18", preferably 24", of working space around the entire unit.