

Revision 3

April 2005



BATCA
fitness systems · usa

B-1

(Flat, Incline, Decline Bench)

Owner's Manual



Record Serial Number Here

Date of Purchase

Batca Fitness Systems
Tel. (919) 255-1233
www.batcafitness.com

Instructions

Congratulations on the purchase of your new Batca B-1 F.I.D. Bench. This bench will provide you with a lifetime of enjoyment to meet your strength training needs. Batca Fitness Systems strives to build the best quality benches and to package them in such a way to avoid any damage during shipping.

In order to get started with your assembly you should first familiarize yourself with this manual. It is recommended that you read through each step thoroughly before you begin. Begin by opening your box and separating all of your parts. Verify that all parts are accounted for and have no damage. When all parts are accounted for, you may begin your assembly. Some items may have been pre-assembled for your convenience. Please note that hardware quantities shown reflect total quantities for your gym and may not reflect actual quantities in each bag. Assemble your bench on a solid level surface. This will ensure the best possible performance, function, and safety for the bench and your workout.

Assemble your bench according to the step by step instructions found in this manual. Failure to do so will void your warranty and may result in personal injury. After assembly you should check your bench for correct operation. If a problem arises, recheck your assembly with these instructions to verify correct assembly. If you are unable to correct a problem or have questions with your assembly please contact your authorized Batca dealer.

Table of contents

	<u>Page</u>
Instructions	2
Parts Listing	3
Hardware Comparison	4-6
Main Frame Assembly	7-8
Upholstery	9
Decline Holddown Attachment	10
Preacher Curl Attachment	11
Maintenance, Warnings	12
Warranty	13
Floor Plan Layout	14

Frame Components

ITEM #	PART #	DESCRIPTION	QTY.
1	BFM-10200	Frame	1
2	BFM-50328	Bent Tube	1
3	BFM-10203	Telspar Assembly	1
4	BFL-50131	Plate	1
5	BFL-50132	Plate	1
6	BFM-10201	Upper Seat Support	1
7	BFM-10202	Lower Seat Support	1
8	BFM-10204	Seat Bottom Adjustment	1
9	BFM-10205	Chrome Adjustment	1
29	BFM-50342	Axle	1
30	BFL-50134	Plate	1

Hardware

ITEM #	PART #	DESCRIPTION	QTY.
10	BFH-50110	Molded Grip	1
11	BFH-50121	HCS 3/8"-16 X 2" P5	2
12	BFH-50123	HCS 3/8"-16 X 2 1/2" P5	5
13	BFH-50125	HCS 3/8"-16 X 3" P5	2
14	BFH-50270	HCS 3/8"-16 X 5 1/4" P5	1
15	BFH-50137	HCS 1/2"-13 X 3 1/4" P5	1
16	BFH-50140	HCS 1/2"-13 X 4 1/2" P5	1
17	BFH-50141	HCS 1/2"-13 X 5 1/2" P5	2
18	BFH-50146	3/8" Flat Washer (Black)	17
19	BFH-50147	3/8" Lock Washer (Black)	5
20	BFH-50155	1/2"-13 Nylock (Black)	4
21	BFH-50157	3/8"-16 Nylock (Black)	7
22	BFH-50223	Wheel	2
23	BFH-50251	1/2" Flat Washer (Black)	8
24	BFH-50265	FHSCS 3/8"-16 X 4 1/4"	2
27	BFH-50257	Warning Label	1
28	BFH-50211	2" Square Plastic Cap	2
31	BFH-50212	2" x 3" Plastic Cap	4
32	BFH-50213	1 1/2" x 2" Plastic Cap	3
33	BFH-50215	1 1/2" Square Plastic Cap	2
34	BFH-50197	Small Logo	1
35	BFH-50175	Sleeve Insert	2
36	BFH-50277	1 1/2" x 3" Plastic Cap	2
37	BFM-50263	Pull Pin T-Handle	N/A
38	BFM-50157	1/2" Short Pull Pin Assembly	2
39	BFH-50272	1/2" Short Twist Lock Pull Pin	1
40	BFH-50278	Silver Metallic Touch-Up Paint	1
41	BFH-50259	Black Wrinkle Touch-Up Paint	1

Upholstery

ITEM #	PART #	DESCRIPTION	QTY.
25	BFU-10115	Back Pad	1
26	BFU-10116	Bottom Pad	1

Tools Required

- 9/16" Wrench
- 3/4" Wrench
- 9/16" Ratchet
- 3/4" Ratchet
- Allen Wrench

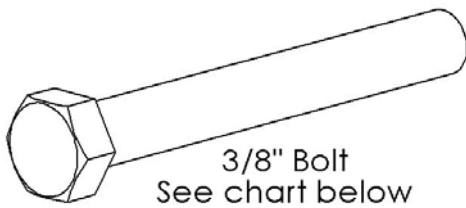

3/8" Bolt
See chart below

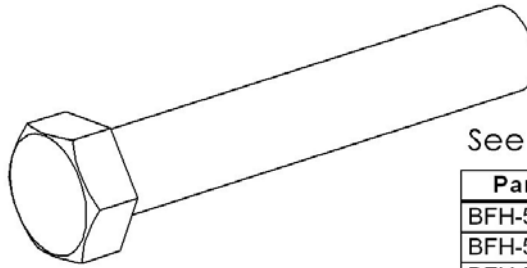

1/2" Bolt
See chart below.

Part #	Size
BFH-50254	3/8" x 3/4"
BFH-50118	3/8" x 1"
BFH-50119	3/8" x 1 1/4"
BFH-50120	3/8" x 1 1/2"
BFH-50285	3/8" x 1 3/4"
BFH-50121	3/8" x 2"
BFH-50122	3/8" x 2 1/4"
BFH-50123	3/8" x 2 1/2"
BFH-50124	3/8" x 2 3/4"
BFH-50125	3/8" x 3"
BFH-50126	3/8" x 3 1/4"
BFH-50127	3/8" x 3 1/2"
BFH-50128	3/8" x 3 3/4"
BFH-50129	3/8" x 4"
BFH-50130	3/8" x 4 1/4"
BFH-50131	3/8" x 4 1/2"
BFH-50274	3/8" x 4 3/4"
BFH-50279	3/8" x 5"
BFH-50270	3/8" x 5 1/4"
BFH-50132	3/8" x 5 1/2"
BFH-50133	3/8" x 6 1/2"
BFH-50298	3/8" x 8 3/4"
BFH-50134	3/8" x 9"

Part #	Size
BFH-50135	1/2" x 2 3/4"
BFH-50136	1/2" x 3"
BFH-50137	1/2" x 3 1/4"
BFH-50138	1/2" x 3 1/2"
BFH-50139	1/2" x 4 1/4"
BFH-50140	1/2" x 4 1/2"
BFH-50141	1/2" x 5 1/2"

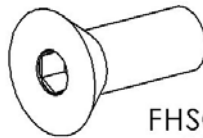

FHSCS 3/8" x 1"
BFH-50144

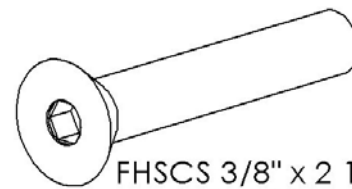

FHSCS 3/8" x 2 1/4"
BFH-50145

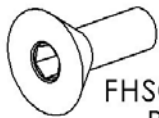

FHSCS 5/16" x 1"
BFH-50245

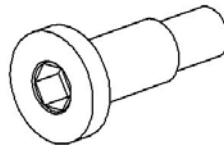

1 1/4" Shoulder Bolt
BFH-50250

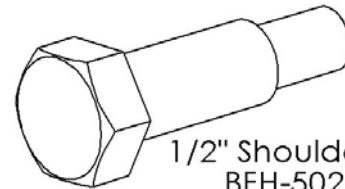

1/2" Shoulder Bolt
BFH-50249

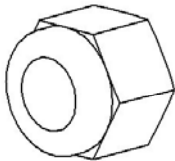

1/2" Nylock
BFH-50155

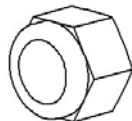

3/8" Nylock
BFH-50157



3/8" Thin Nylock
BFH-50247

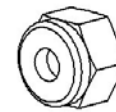

5/16" Nylock
BFH-50267

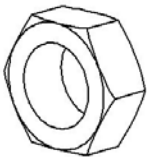

1/2" Jam Nut
BFH-50256

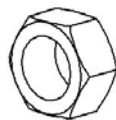

3/8" Jam Nut
BFH-50149

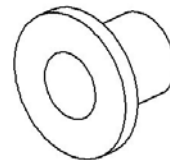

1/2" Pulley Spacer
BFH-50201

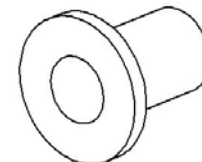

3/4" Pulley Spacer
BFH-50202

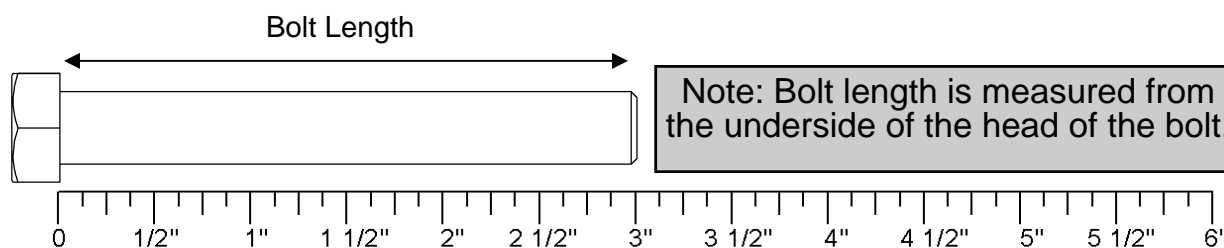

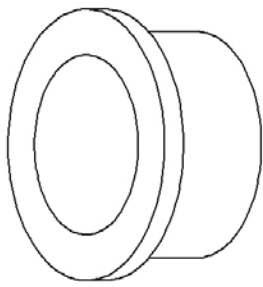

1" Bronze Bushing
BFH-50101

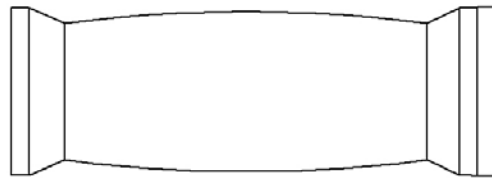

Molded Grip - BFH-50110

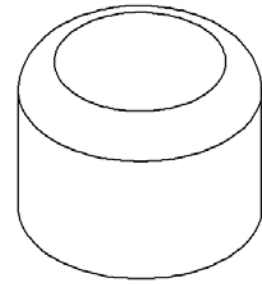

1" Outer Plastic Cap
BFH-50111

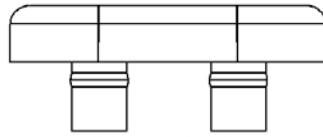

BFH-50222

Rubber Bumpers

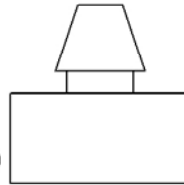

BFH-50200

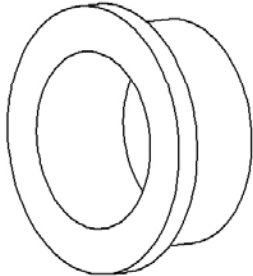

1" Bronze Bushing x 1/2 L
BFH-50297

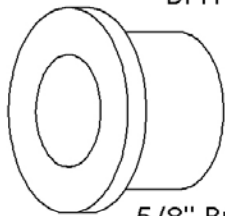

5/8" Bronze Bushing
BFH-50102

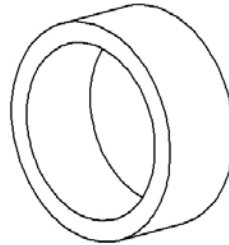

5/8" Spacer
BFM-50247

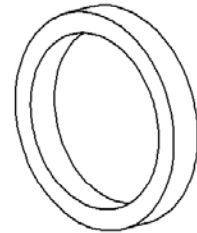

3/16" Spacer
BFM-50246

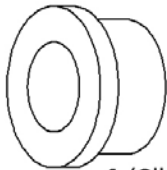

1/2" Bronze Bushing
BFH-50103

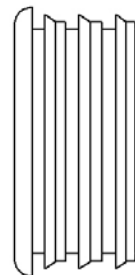

1 1/2" Inner Plastic Cap
BFH-50114



Cable Pivot Bushing
BFH-50248

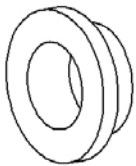

Short 1/2" Bushing
BFH-50244

1" Inner Plastic Cap
BFH-50280

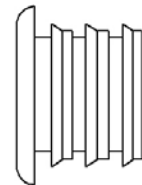

1/2" Snap Ring
BFH-50166

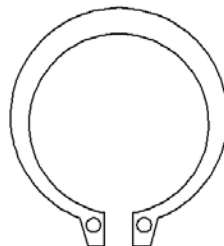

1" Snap Ring
BFH-50165

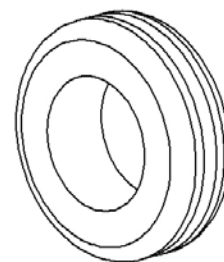

Rubber Grommet
BFH-50199

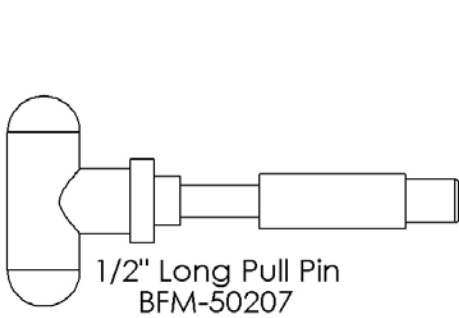

1/2" Long Pull Pin
BFM-50207

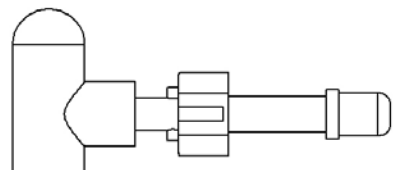

1/2" Twist Lock Pull Pin
BFH-50272

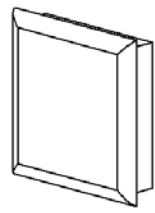

Plastic Cap

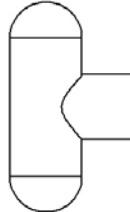

Pull Pin T-Handle
BFM-50263

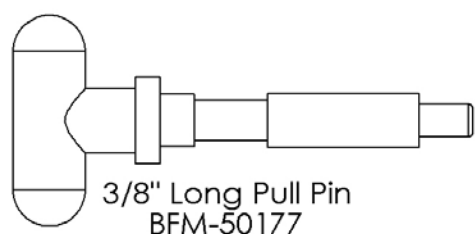

3/8" Long Pull Pin
BFM-50177

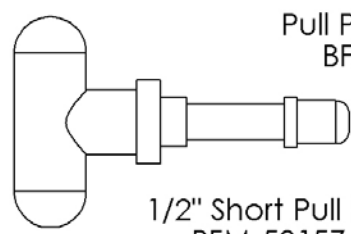

1/2" Short Pull Pin
BFM-50157

Part #	Size
BFH-50211	2" x 2"
BFH-50212	2" x 3"
BFH-50213	1 1/2" x 2"
BFH-50214	1 3/4" x 1 3/4"
BFH-50215	1 1/2" x 1 1/2"

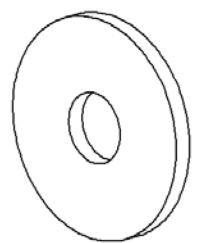

3/8" Fender Washer
BFH-50242

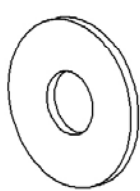

3/8" Flat Washer
BFH-50146

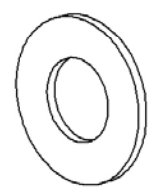

1/2" Flat Washer
BFH-50251

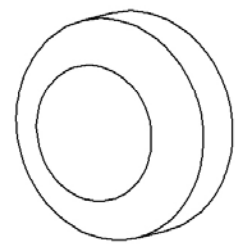

Screw Cap Cover
BFH-50112

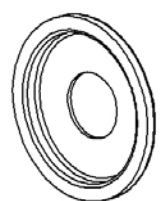

Screw Cap Washer
BFH-50113



3/8" Lock Washer
BFH-50147

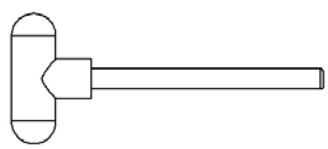

Weight Stack Pin
BFC-50127

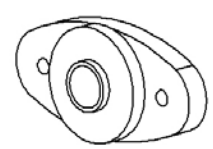

Side Mounted
Flange Bearing
BFH-50171

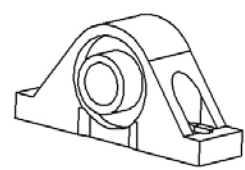

Pillow Block Bearing
BFH-50172

Items not shown.

Part #	Description
BFH-50259	Midnight Black Paint
BFH-50278	Silver Metallic Paint
BFH-50198	Large Logo
BFH-50197	Small Logo
BFH-50236	Foam Grip
BFH-50246	Anti Skid
BFH-50262	Silicon Gel Pack
BFC-10101	1 inch chain
BFC-10102	12 inch chain

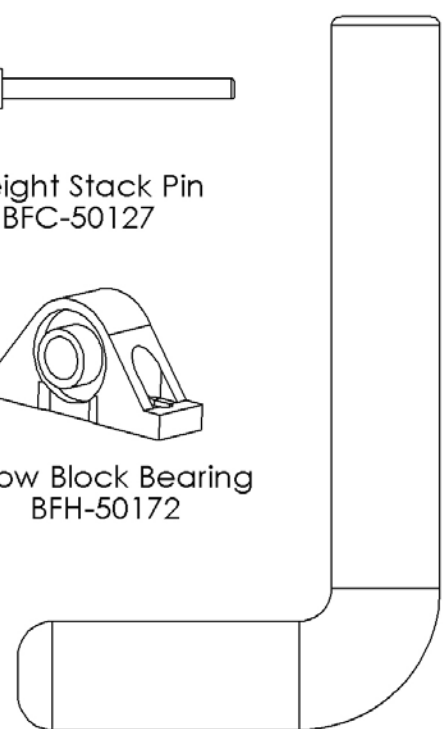

Bar Catch Rubber Sleeve
BFH-50240

PLEASE FOLLOW ALL DIRECTIONS VERY CAREFULLY FOR PROPER INSTALLATION.

Step 1:



Note: It is very important that the HCS 1/2"-13 x 4 1/2" bolt is not over tightened. This may affect the operation of the bench seat's hinge and could cause the movement to bind.

Note: For a more consistent appearance, position all bolts in the direction shown in each figure.

- **Record** your serial number on the front of this assembly instructions and keep for your records. The serial number can be found on the inside face of the back left leg of the bench Frame (1) as seen in Figure 1A.
- All Flat Washers and Nylocks are 3/8" unless otherwise noted.

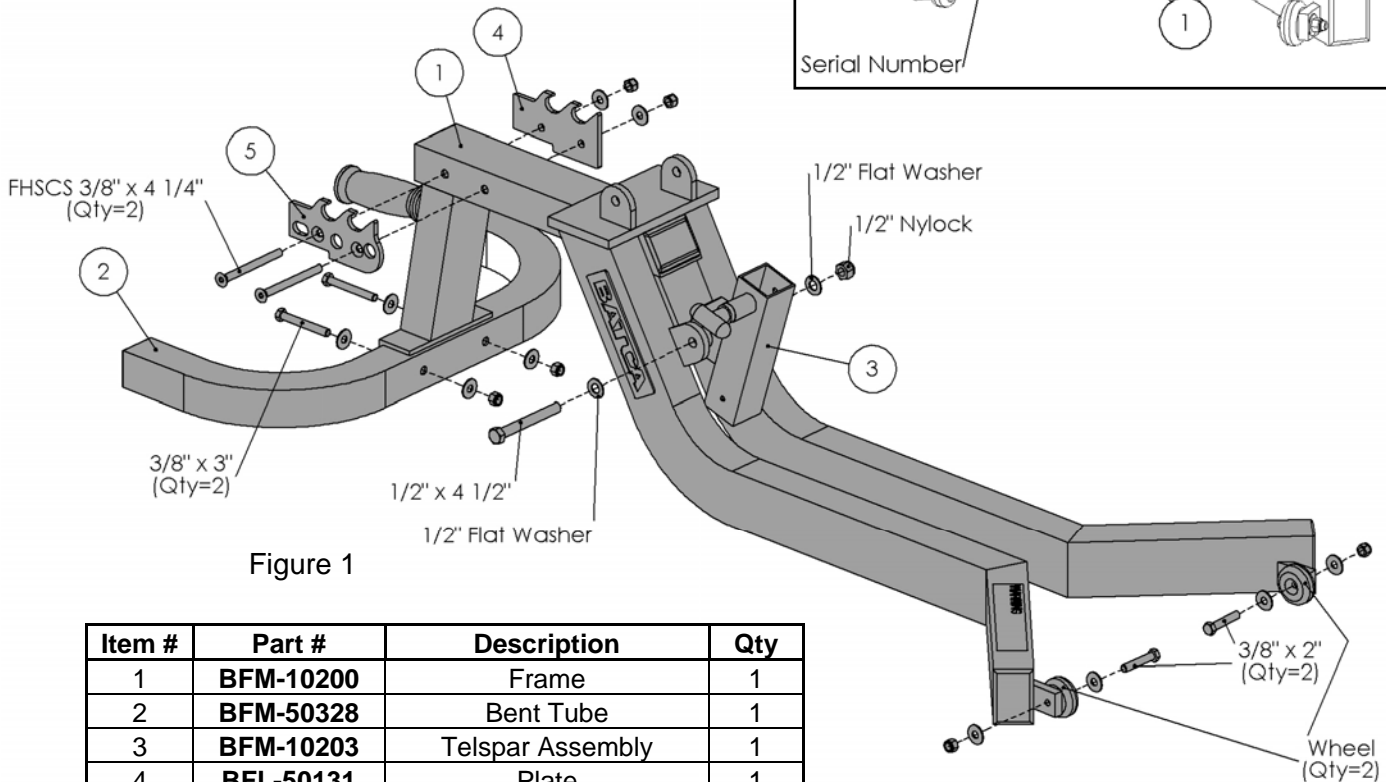
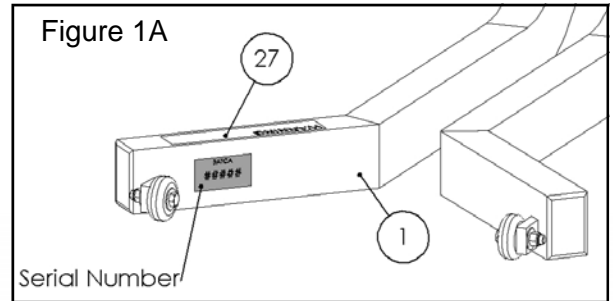

Figure 1

Item #	Part #	Description	Qty
1	BFM-10200	Frame	1
2	BFM-50328	Bent Tube	1
3	BFM-10203	Telspar Assembly	1
4	BFL-50131	Plate	1
5	BFL-50132	Plate	1
11	BFH-50121	HCS 3/8"-16 X 2" P5	2
13	BFH-50125	HCS 3/8"-16 X 3" P5	2
16	BFH-50140	HCS 1/2-13 X 4 1/2" P5	1
18	BFH-50146	3/8" Flat Washer (Black)	10
20	BFH-50155	1/2"-13 Nylock (Black)	1
21	BFH-50157	3/8"-16 Nylock (Black)	6
22	BFH-50223	Wheel	2
23	BFH-50251	1/2" Flat Washer (Black)	2
24	BFH-50265	FHSCS 3/8"-16 X 4 1/4"	2
27	BFH-50257	Warning Label	1

Step 2:



Note: It is very important that the HCS 1/2"-13 x 5 1/2" and HCS 1/2"-13 x 3 1/4" bolts are not over tightened. This may affect the operation of the bench seat's hinge and could cause the movement to bind.

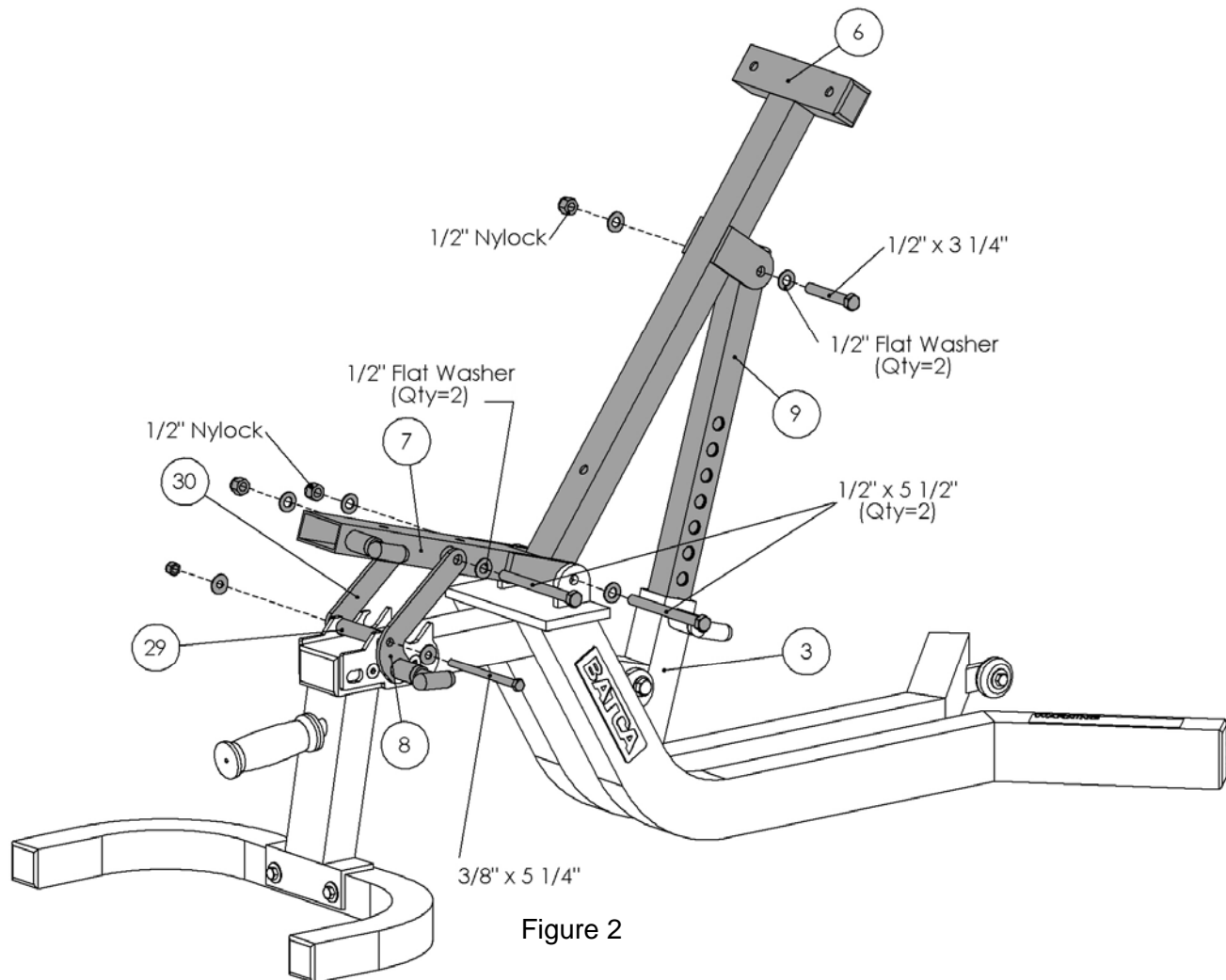

Figure 2

Item #	Part #	Description	Qty
6	BFM-10201	Upper Seat Support	1
7	BFM-10202	Lower Seat Support	1
8	BFM-10204	Seat Bottom Adjustment	1
9	BFM-10205	Chrome Adjustment	1
29	BFM-50342	Axle	1
30	BFL-50134	Plate	1
14	BFH-50270	HCS 3/8"-16 X 5 1/4" P5	1
15	BFH-50137	HCS 1/2"-13 X 3 1/4" P5	1
17	BFH-50141	HCS 1/2-13 X 5 1/2 P5	2
18	BFH-50146	3/8" Flat Washer (Black)	2
20	BFH-50155	1/2"-13 Nylock (Black)	3
21	BFH-50157	3/8"-16 Nylock (Black)	1
23	BFH-50251	1/2" Flat Washer	6

All Flat Washers and Nylocks are 3/8" unless otherwise noted.

Step 3:



Note: All bolts in this step receive one 3/8" Flat Washer and one 3/8" Lock Washer instead of one 3/8" Nylock.

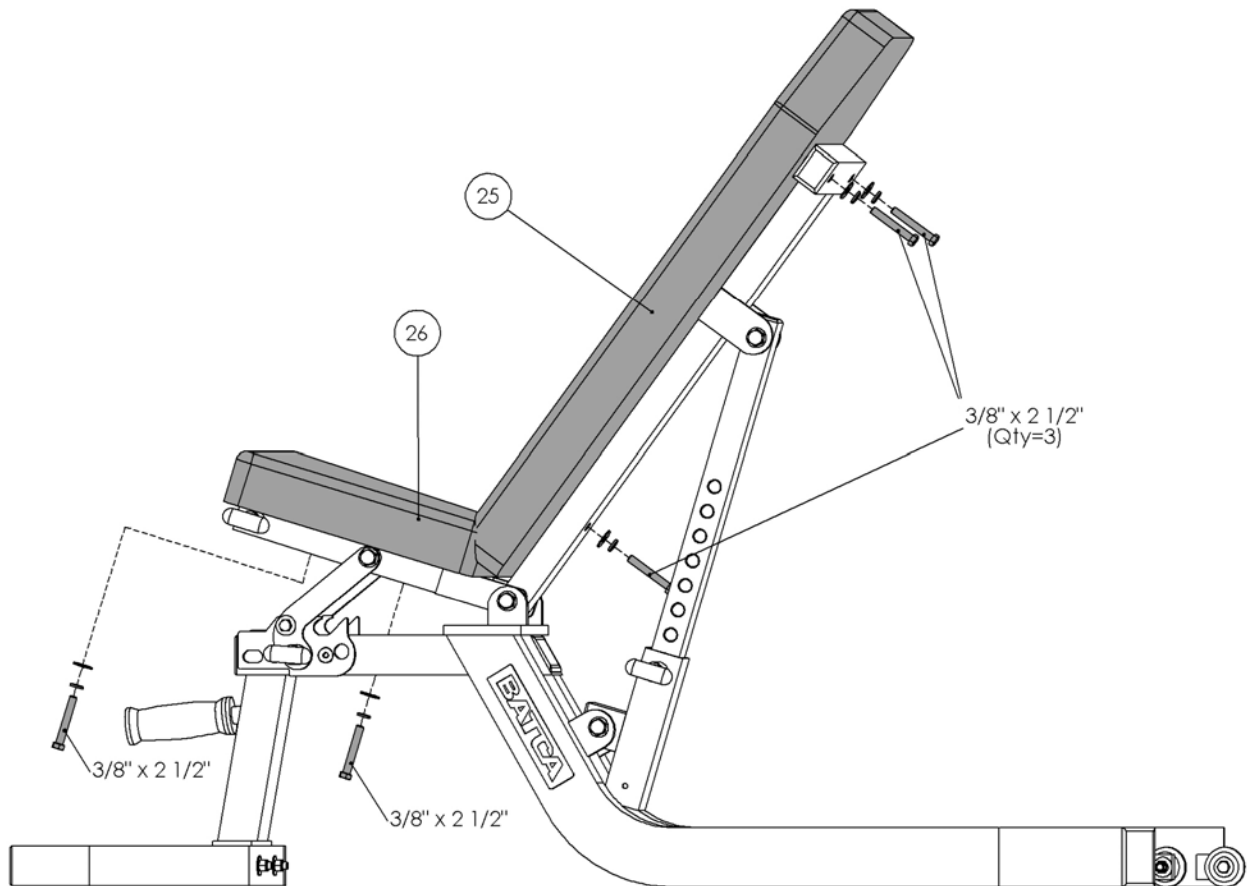
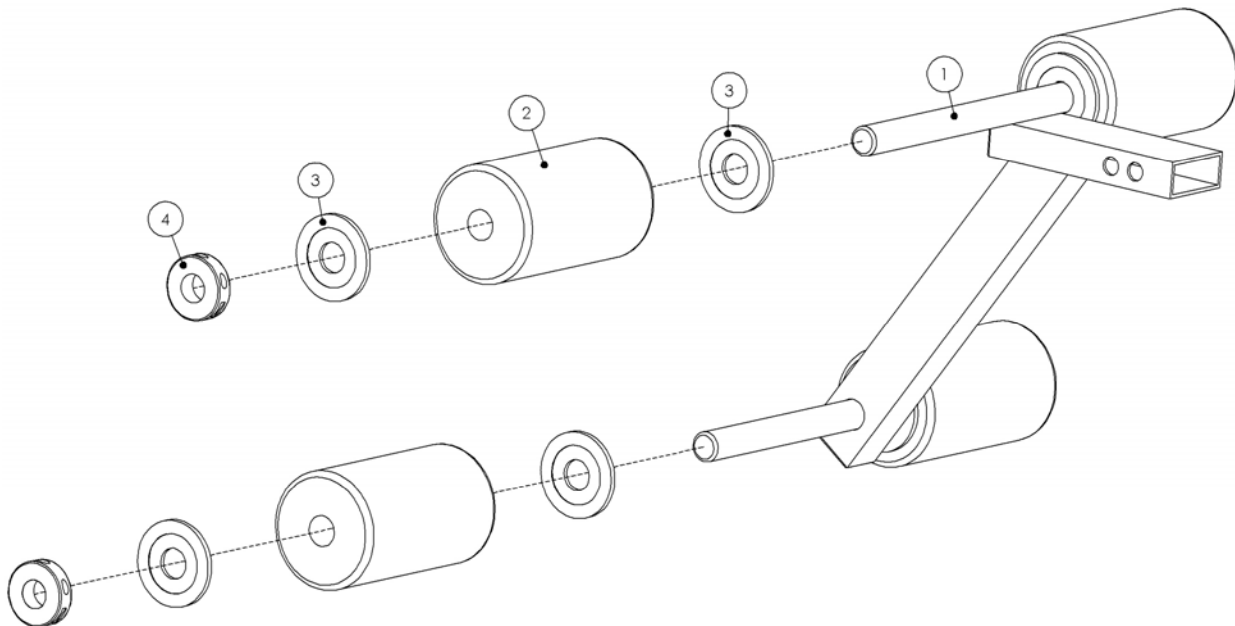
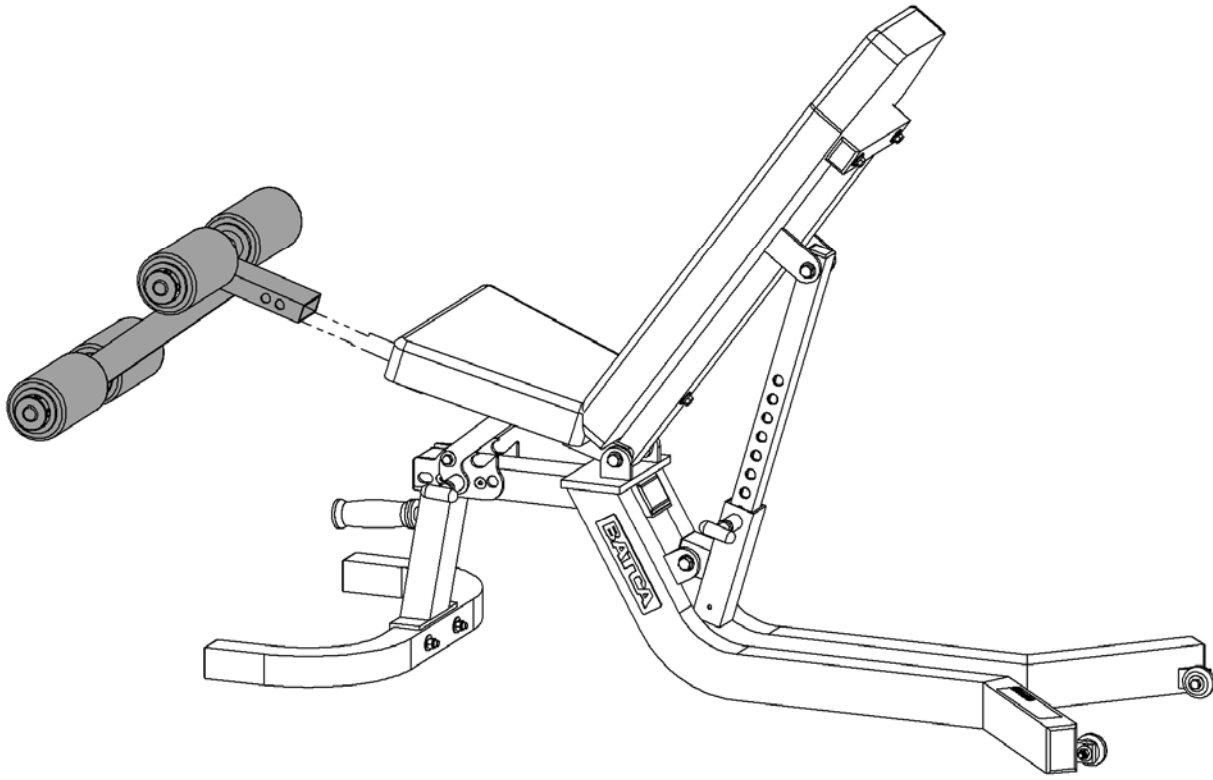

Figure 3

Item #	Part #	Description	Qty
12	BFH-50123	HCS 3/8"-16 X 2 1/2" P5	5
18	BFH-50146	3/8" Flat Washer (Black)	5
19	BFH-50147	3/8" Lock Washer (Black)	5
25	BFU-10115	Back Pad	1
26	BFU-10116	Bottom Pad	1

All Flat Washers and Nylocks are 3/8" unless otherwise noted.

Decline Holddown Attachment:



Item #	Part #	Description	Qty
1	BFM-10433	Decline Holddown Attachment	1
2	BFU-10121	7" Upholstery Roller	4
3	BFH-50221	3" Plastic Washer	8
4	BFH-50252	Plastic Collar	4

Preacher Curl Attachment:

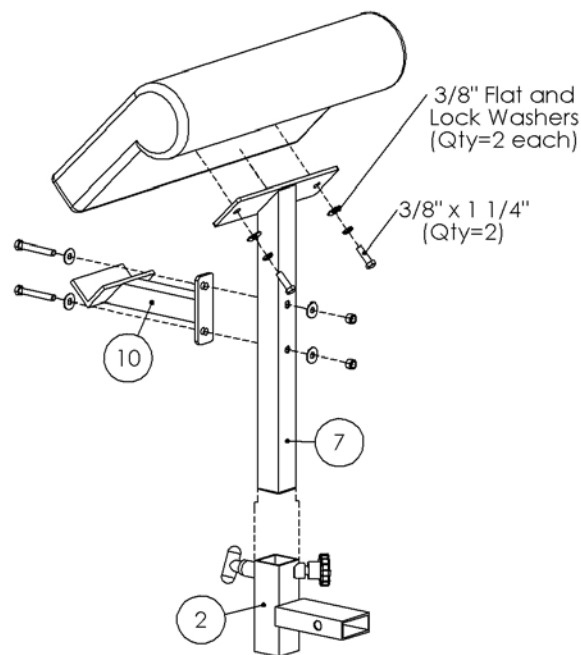
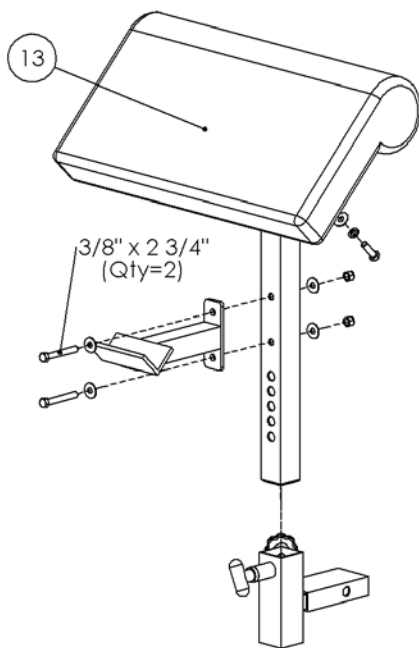
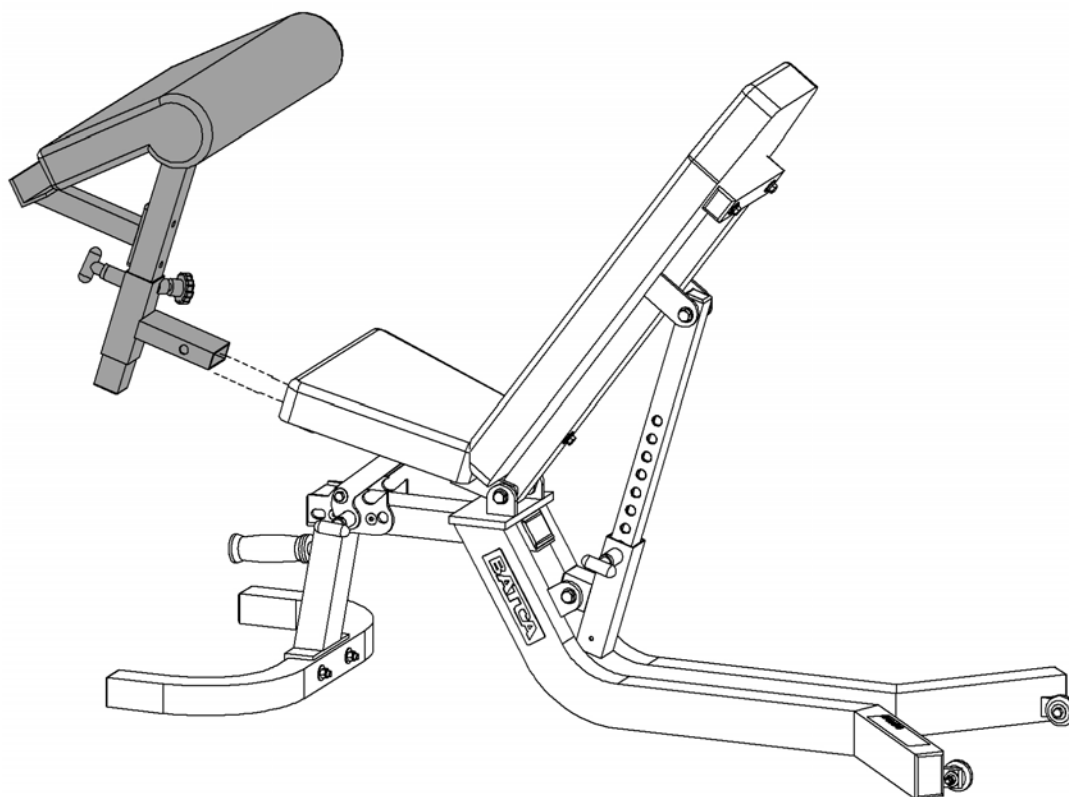

Item #	Part #	Description	Qty
1	BFM-10434	Preacher Curl Adjustment	1
2	BFM-10435	Elbow Support	1
3	BFM-10436	Bar Holder	1
4	BFU-10139	Preacher Curl Pad	1
5	BFH-50146	3/8" Flat Washer (Black)	6

Item #	Part #	Description	Qty
6	BFH-50157	3/8"-16 Nylock (Black)	2
7	BFH-50124	HCS 3/8"-16 X 2 3/4" P5	2
8	BFH-50147	3/8" Lock Washer (Black)	2
9	BFH-50119	HCS 3/8"-16 X 1 1/4" P5	2

Preventive Maintenance and Warnings

Batca Fitness Systems strives to give you the very best in quality, performance and safety through carefully engineered designs and excellent workmanship. In order to maintain this high level of quality the preventative maintenance schedule below should be followed.

Clean upholstery and grips with mild soap and water generally after every use. The chrome slides and frame should be cleaned with a cotton cloth.

A visual overall inspection should be done before each workout. If the warning and safety decals are worn or have been removed they should be replaced immediately. Replace any part at first signs of wear. All hardware, stops, and adjustments should be checked and tightened as required.

	Daily		Weekly		Monthly		Quarterly	
	Commercial	Home	Commercial	Home	Commercial	Home	Commercial	Home
Clean								
Upholstery	X			X				
Hand Grip	X			X				
Frame			X			X		
Inspect								
Overall	X	X						
Safety Decals	X	X						
Hardware	X	X						
Upholstery	X	X						
Hand Grip			X			X		
Frame			X			X		
Bushings	X			X				
Bearings	X			X				

WARNING: There is a risk assumed by individuals who use this type of equipment. To minimize risk always follow these rules.

- 1) It is essential that you consult with your physician before beginning any exercise program.
- 2) Inspect equipment before each use for loose, worn, or frayed parts (including cables, nuts and bolts). Replace parts at first signs of wear (use only genuine BATCA replacement parts). Use of equipment that is damaged, worn, frayed or not completely assembled on a solid, level surface may result in injury.
- 3) Make sure all adjustment pins are fully engaged before using equipment.
- 4) Keep all parts of the body and clothing outside the path of any moving parts of the machine. Be alert to the possibility of injury. Do not be careless.
- 5) Minors and children should not be allowed to play on or around this machine.
- 6) If you have any questions on proper use or maintenance of this machine, do not hesitate to call your local BATCA FITNESS SYSTEMS distributor or BATCA FITNESS SYSTEMS at (919) 255-1233. www.batcafitness.com

Limited Lifetime Warranty

What is covered

For Residential Use:

Batca Fitness Systems warrants all of its products against defects in manufacturing, materials and workmanship under normal use and service for one year from date of purchase including paint, chrome, upholstery and grips. Batca Fitness Systems also warrants all cables, belts, bolts, nuts, caps, plugs, bumpers, washers, levelers, decals, gas springs and other hardware for three years after date of purchase; all moving parts, including pulleys, bushings, bearings and pull pins for five years after date of purchase and warrants the frame and all welded parts for the lifetime of the original purchaser.

For Commercial Use:

Batca Fitness Systems warrants all of its products against defects in manufacturing, materials and workmanship under normal use and service for six months from date of purchase including paint, chrome, upholstery and grips. Batca Fitness Systems also warrants all cables, belts, bolts, nuts, caps, plugs, bumpers, washers, levelers, decals, gas springs and other hardware for one year after date of purchase; all moving parts, including pulleys, bushings, bearings and pull pins for three years after date of purchase and warrants the frame and all welded parts for ten years after date of purchase.

What is not covered

This warranty does not cover damage, which results from shipping, misuse, abuse, neglect, carelessness, modification or alteration, accident, fire, flood, "acts of God" or other contingencies beyond the control of Batca Fitness Systems. This warranty also does not cover deterioration from wear and tear or exposure or any defect, which would not have happened if instructions in the owner's manual had been followed. Improper installation, improper assembly or follow-up maintenance along with installation of parts or accessories not originally intended for products of Batca Fitness Systems are also not covered by this warranty. Only genuine Batca parts should be used for replacement, repair, and maintenance for this warranty to apply.

Defective parts will be repaired or replaced at Batca Fitness Systems option, without parts charge to the purchaser. All returns require a return authorization prior to acceptance of repair work. Batca Fitness Systems reserves the right to make design changes without any prior notification and shall not be responsible for incidental or consequential damages.

The purchaser is responsible for shipping the defective part back to the factory. Repair or replacement is the exclusive and sole remedy of the purchaser. Labor charges associated with parts changeovers are not covered by this warranty. Proof of purchase, serial number, model number and date of purchase will be required along with all pertinent information of the alleged damage.

This warranty applies only to the original purchaser and is not transferable. Claims under this warranty must be made directly to Batca Fitness Systems.

Batca Fitness Systems
1207 N. New Hope Road
Raleigh, NC 27610
(919) 255-1233

www.batcafitness.com

Please keep this for your records.

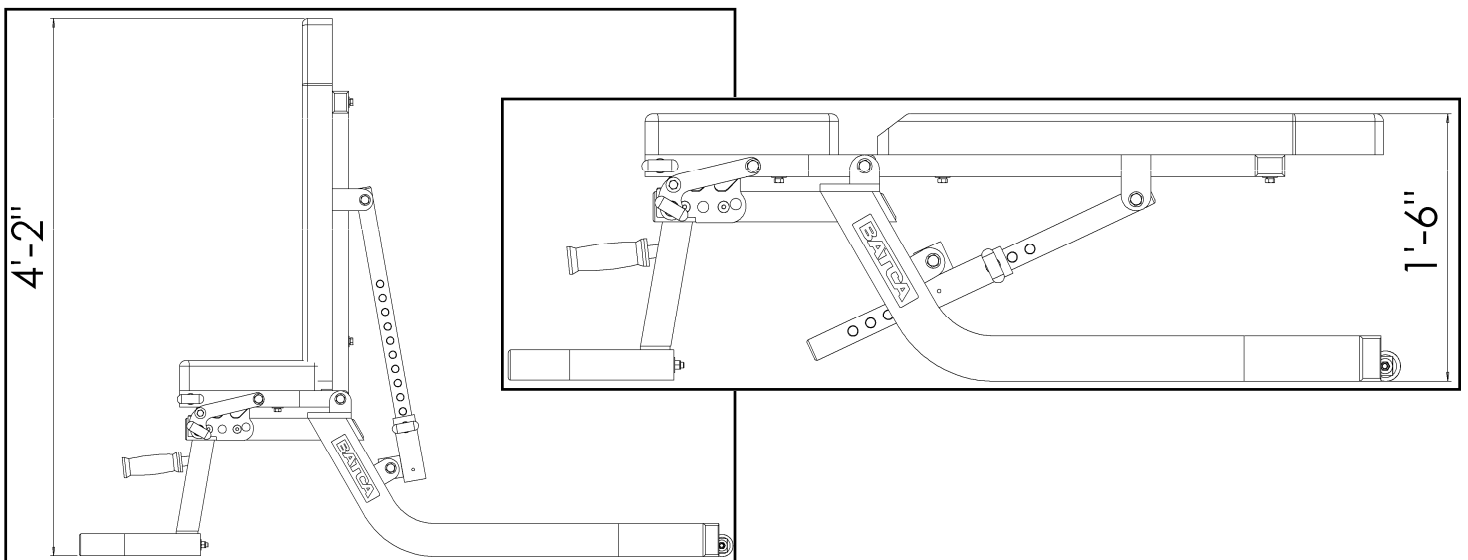
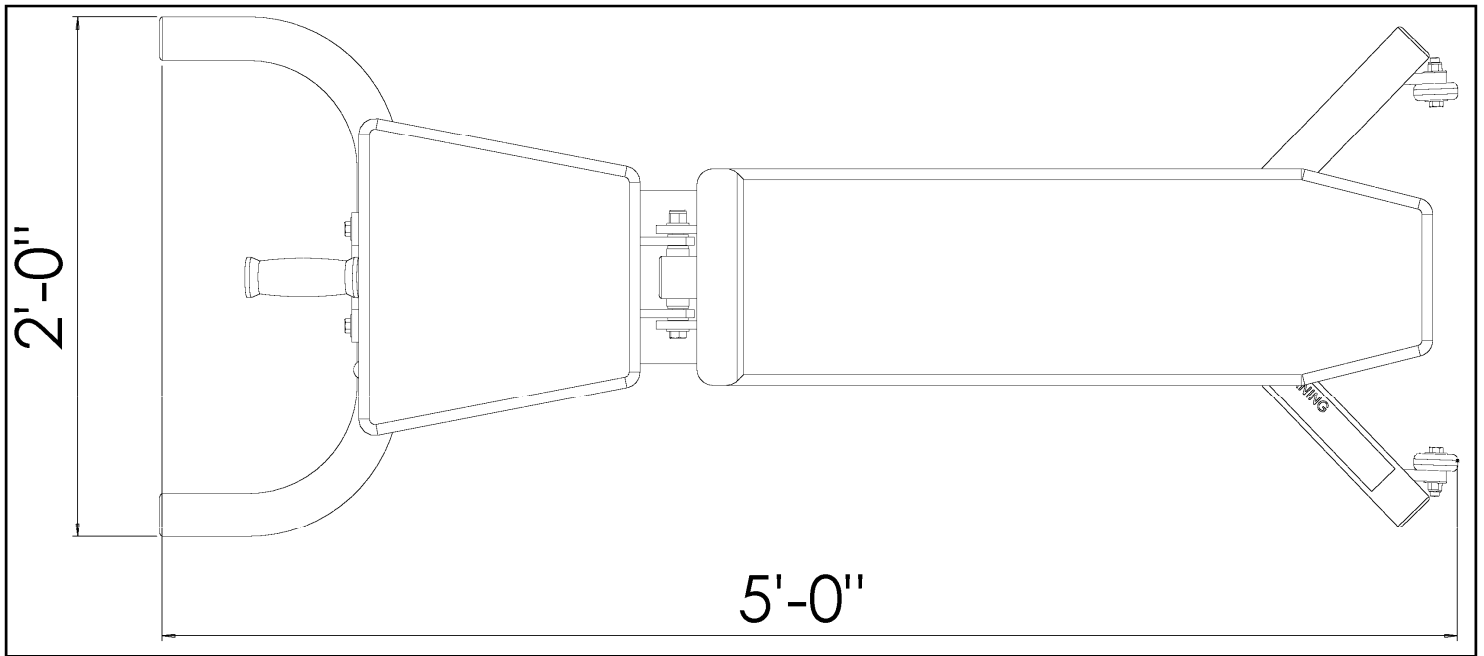

Layout Diagram

The FID Bench has a layout dimension of 5'-0" (length) x 2'-0" (width) x 1'-6" (height) laying flat and 4'-2" (height) sitting up straight. There should be a minimum of 18", preferably 24", of working space around the entire unit.