

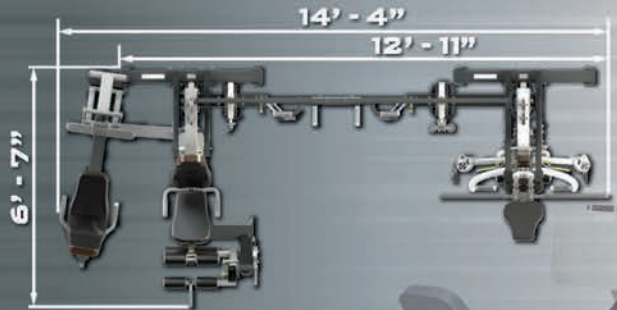

BATCA
fitness systems usa

FUSION 4 CARBON EDITION



HEIGHT: 7'-2"
WEIGHT:
FZ-5 - 729 LBS
TOTAL WEIGHT OF
COMPLETE SYSTEM:
2,051 LBS



****FZ-5 IS NOT FREE STANDING AND
REQUIRES SUPPORT OF FZ-1 AND FZ-3**

FZ-5 FUNCTIONAL TRAINER

FREE CABLE EXERCISES -
ADJUSTABLE DUAL PULLEYS OFFER
LIMITLESS FREE CABLE EXERCISE
PATTERNS

BAR EXERCISES -
PERFORM SQUATS, CURLS, ROWS,
AND MORE WITH STANDARD BAR
ATTACHMENT

CHIN UP -
WIDE AND NEUTRAL HAND GRIPS
*** BENCH EXERCISES -**
USING OPTIONAL FZ-6 F.I.D. BENCH

FZ-3 LOWER BODY UNIT

SEATED LEG CURL/LEG EXTENSION -
PATENTED KNEE ALIGNMENT PADS
CONTOURED AND TELESCOPING BACK PAD
8 STARTING POINT ADJUSTMENTS
COUNTER BALANCED EXERCISE ARM

FZ-4 LEG PRESS/ CALF RAISE -
WALK THROUGH FRAME DESIGN
LARGE FOOT PLATE
FOUR BAR LINKAGE
2 TO 1 WEIGHT RATIO

* OPTIONAL
FZ-4
LEG PRESS



HEIGHT: 6'-3"
WEIGHT:
FZ-3 - 610 LBS
FZ-4 - 154 LBS

FZ-1 UPPER BODY UNIT

DUAL SWIVELING HIGH PULLEYS -
STRAIGHT OR SIDE AB CRUNCH
ISOLATERAL OR BAR LAT PULL

MULTI-PRESS ARMS -
CHEST/INCLINE/DECLINE PRESS
CHEST SUPPORTED MID ROW

FZ-2 OPTIONAL CABLE ARMS -
SHOULDER PRESS, PEC FLY, BICEP CURL,
TRICEP EXTENSION, AND A
MULTITUDE OF FREE CABLE
EXERCISES

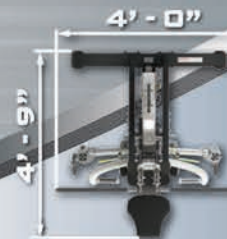

HEIGHT: 6'-11"
WEIGHT:
FZ-1 520 LBS
FZ-2 38 LBS



* OPTIONAL
FZ-2
CABLE
ARMS

FUSION 4 ELEMENTS